

GSV

Gas Solenoid Valve

Installation and Maintenance Instructions



In this procedure document we have endeavoured to make the information as accurate as possible.

We cannot accept any responsibility should it be found that in any respect the information is inaccurate or incomplete or becomes so as a result of further developments or otherwise.

INTRODUCTION

The Gold Seal GSV solenoid valves are widely used in gas distribution to provide isolation and emergency shut-off.

The valves can be used on various hydrocarbon gases including natural gas, methane, and liquid petroleum gas.

OPERATION

The GSV solenoid valves will normally be in the closed position, but when energised will open quickly and a blue indicator light will be lit on the terminal box attached to the coil.

There are G $\frac{1}{4}$ holes on both sides of the valve body and at the bottom. These can be used for various applications but notably a CPI (closed position indicator) or gas proving system.

TECHNICAL SPECIFICATION

Opening time:		< 1 second
Closing time:		< 1 second
Max. operating frequency:		20 time per minute
Maximum working pressure:	$\frac{1}{2}$ " to 1"	360 mbar
	1 $\frac{1}{4}$ " to 2"	200 mbar
Integral filter:		
Protection level:		IP54
Working temperature:		-15 to 60 °C
Coil temperature:		65 °C
Body connections:		BS EN 10226
Seal material:		NBR polymer
Body material:		Aluminium alloy
Spring material:		AISI 302 stainless steel

ELECTRICAL SPECIFICATION

Voltage:	230 V ac & 110 V ac
Rating:	50/60 Hz
Coil Level F:	360 ° rotation
Suitable for:	Permanent excitation

STANDARDS

According to European Standards:	90/396/EEC
	73/23/EEC
	89/336/EEC
According to standard:	EN 161

DIMENSIONS

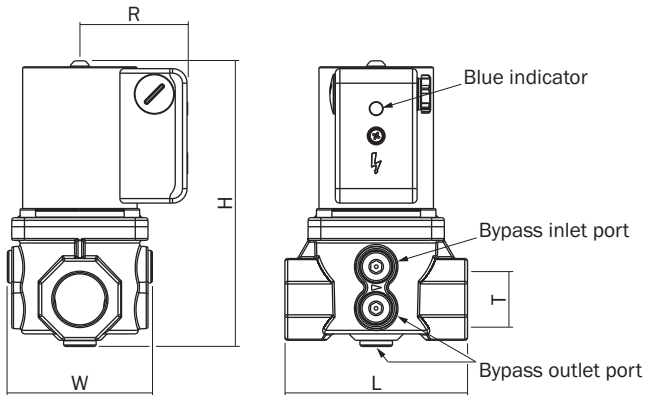

Code	T	L	W	H	R	230V AC Power - W
GSV15	Rp½	72	71	115	55	15
GSV20	Rp¾	92	76	156	59	22
GSV25	Rp1	100	80	158	59	22
GSV32	Rp1¼	149	115	216	71	42
GSV40	Rp1½	149	115	216	71	42
GSV50	Rp2	170	142	230	76	50

CAPACITY

The capacity in m³/hr at ΔP = 2.5 mbar.

Code	Size	m ³ /hr
GSV15	½"	6.4
GSV20	¾"	14.8
GSV25	1"	16.7
GSV32	1¼"	38.5
GSV40	1½"	47.1
GSV50	2"	66.7

PRESSURE DROP CHART

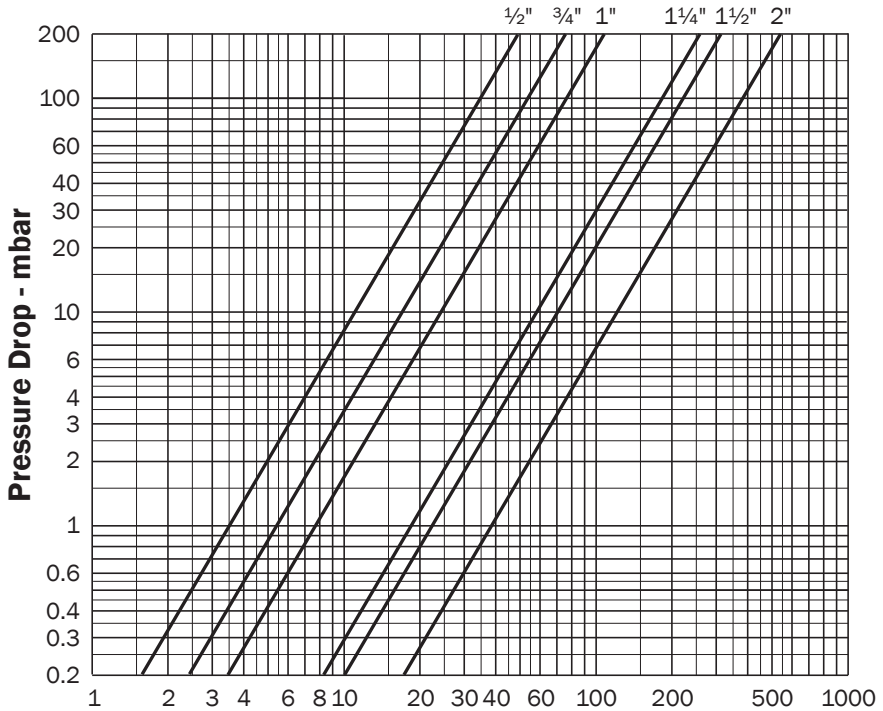

Based on +15°C, 1013 mbar, dry **Air Flow - Nm³/h**

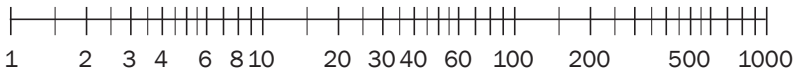

Based on f = 1.24 **Natural Gas Flow - Nm³/h**

$$dv = \frac{\text{Gas density}}{\text{Air density}}$$

$$f = \sqrt{\frac{\text{Relative density of air}}{\text{Relative density of gas}}}$$

Gas	Density kg/m ³	dv density ratio	f correction factor
Air	1.29	1.00	1.00
Natural gas	0.84	0.65	1.24
Liquid gas	2.19	1.70	0.77

ELECTRICAL INSTALLATION

- Turn off power supply before making electrical connections or servicing any part of the system.
- Provide a fused isolation switch for the power supply to the actuator.
- Ensure that wiring is in accordance with local regulations.
- Use wire which can withstand 105 °C ambient.
- Follow the instructions supplied by the appliance manufacture.

INSTALLATION

If installing the gas solenoid valve into an existing system;

- Turn off gas supply before starting installation.
- Disconnect power supply to prevent electrical shock and/or equipment damage.
- Take care to ensure that dirt cannot enter the gas valve during handling and installation.

General installation recommendations;

- The GSV gas solenoid valve should be mounted directly in a vertical pipeline or in a horizontal pipeline with the coil uppermost.
- Check that the site conditions comply with the technical specification of the valve.
- The flow direction arrow on the valve body must match the direction of flow.
- Thoroughly purge the pipeline before installing the valve to prevent debris entering the valve and damaging the diaphragm and causing premature failure.
- A gas filter should be installed upstream of the valve to prevent the ingress of debris and prolong the interval between services and the life of the valve.
- **IMPORTANT:** the valve is not explosion proof.
- If installed outdoors or in a harsh environment the valve should be protected accordingly.
- If recommended install a bypass around the gas solenoid valve to aid isolation and future maintenance
- If the valve fails to open or close check that the power supply is connected correctly and turned on. Also check the pressure within the system is within the technical specification of the valve.
- If not installed on the valve, the coil should be stored indoors between 0 to 40 °C with a relative humidity of 80% or less. It should not be stored the open air.

COIL CARE

The coil can only be powered when attached to the valve. The power must be disconnected if the coil is removed from the valve, failure to do this will result in the coil burning out.

Never energise the coil if not fitted to the valve otherwise this will shorten its life and eventually result in failure.

The coil should be securely fitted to valve, loose fitting will shorten the life of the coil.

Surge/spikes should be prevented from reaching the coil as this will result in failure.

The power supply must be within the tolerance indicated otherwise failure of the capacitor will occur.

The continuous service (100%ED) causes inevitable coil heating.

Depending on working environment the coil surface will be very hot. This situation is absolutely normal.

DECLARATION OF CONFORMITY

According to European Directive 90/396/EEC -73/23/EEC-89/336/EEC.

KIWA EU type examination certificate (GAR) certificate number 19GR0652/00 - meets the essential requirements as described in regulation (EU) 2016/426 relating to appliances burning gaseous fuels, reference standard EN161:2011+A3:2013.

NOTES:



67 Chorley Old Road
Bolton
BL1 3AJ

Tel: 03300 552885
email: info@goldsealvalves.com
web: www.goldsealvalves.com

E & O.E

03-02-20