

MERLIN 1000BH

Gas Proving & Gas Detection Controller



INSTALLATION & OPERATION MANUAL

Please read these instructions carefully and retain for future use.

These instructions can be downloaded in electronic form on the product website (www.snsnorthern.com) or a printed version can be ordered free of charge via S&S Northern Limited.



Contents

IMPORTANT INFORMATION	3
Copyrights	3
Manufacturer's Warranty	3
Disposing of Electrical & Electronic Equipment (WEEE)	3
Revisions	3
Maintenance	3
Warning Symbol	4
INSTALLATION	4
General Safety Cautions	4
EMI and RF Interference Considerations	4
General Product Information	4
Access & Mounting	5
Electrical Connections	5
Auto Reset Dipswitch	8
BMS SEL Dipswitch	9
Fill & Prove Time Dipswitch	9
OPERATION	9
Initial Power Up	9
Emergency Stop	10
LED Indications	10
MAINTAINENCE	11
Cleaning	11
SPECIFICATION	11

IMPORTANT INFORMATION

Copyrights

This manual is subject to copyright protection; all rights are reserved. Under international and domestic copyright laws, this manual may not be copied or translated, in whole or in part, in any manner or format, without the written permission of **S&S Northern Limited**

Manufacturer's Warranty

The manufacturer warrants to the original consumer purchaser, that this product will be free of defects in material and workmanship for a period of **three (3) years**. The manufacturer's liability hereunder is limited to replacement of the product with repaired product at the discretion of the manufacturer. This warranty is void if the product has been damaged by accident, unreasonable use, neglect, tampering or other causes not arising from defects in material or workmanship. This warranty extends to the original consumer purchaser of the product only. Any implied warranties arising out of this sale, including but not limited to the implied warranties of description, merchantability and intended operational purpose, are limited in duration to the above warranty period. In no event shall the manufacturer be liable for loss of use of this product or for any indirect, special, incidental, or consequential damages, or costs, or expenses incurred by the consumer or any other user of this product, whether due to a breach of contract, negligence, strict liability in tort or otherwise. The manufacturer shall have no liability for any personal injury, property damage or any special, incidental, contingent, or consequential damage of any kind resulting from gas leakage, fire, or explosion. This warranty does not affect your statutory rights. During the above warranty period, your product will be replaced with a comparable product if the defective product is returned together with proof of purchase date. The replacement product will be in warranty for the remainder of the original warranty period or for six months – whichever is the greatest.

Disposing of Electrical & Electronic Equipment (WEEE)

When this product has reached the end of its life it must be treated as Waste Electrical & Electronics Equipment (WEEE). Any WEEE marked products must not be mixed with general household waste, but kept separate for the treatment, recovery and recycling of the materials used. Please contact your supplier or local authority for details of recycling schemes in your area.

Revisions

Every effort is made to ensure the accuracy of this document; however, **S&S** can assume no responsibility for any errors or omissions in this document or their consequences. **S&S** would greatly appreciate being informed of any errors or omissions that may be found in the content of this document. For information not covered in this document, or if there is a requirement to send comments/corrections, please contact **S&S** using the contact details given below.

Maintenance

Gas Detection equipment must be inspected and serviced regularly by suitably qualified persons. Repair of the apparatus may only be carried out by trained service personnel.

Warning Symbol

- ⚠ Where this symbol is used, consult manual to understand any potential hazards and how to avoid them.
- ⚠ **The information contained within this manual should be referenced for typical installation and operation only.**
- ⚠ **Isolate the equipment from all hazardous live power sources before opening the cover.**
- ⚠ **Any parts that form part of the connections/installation must have a minimum fire-retardant rating of UL 94 V-1.**
- ⚠ **For site specific requirements that may deviate from the information in this guide – contact your supplier.**
- ⚠ **If the equipment is used in a manner not specified, the safety provided by the equipment may be impaired.**
- ⚠ **This device is designed for indoor operation only.**
- ⚠ **Never ignore your device when in alarm.**
- ⚠ **This device requires a continual supply of electrical power – it will not work without power.**
- ⚠ **This device should not be used to substitute proper installation, use and/or maintenance of fuel burning appliances including appropriate ventilation and exhaust systems.**
- ⚠ **The device is not intended for use in potentially explosive atmospheres.**
- ⚠ **Your product should reach you in perfect condition, if you suspect it is damaged, contact your supplier.**

INSTALLATION

General Safety Cautions

Failure to observe the following may cause injury to persons and/or property.

Installation must be carried out by a licenced and insured contractor and installed in areas at risk of gas leaks and higher concentrated areas e.g., near boilers, valves, or areas of critical protection, located in positions determined by those who have knowledge of gas dispersion, the process plant system and equipment involved, and in consultation with both safety and electrical engineering personnel.

EMI and RF Interference Considerations

All electronic devices are susceptible to EMI (Electromagnetic Interference) and RFI (Radio Frequency Interference). Our products are designed to reduce the effects of these interferences. However, there are still circumstances and levels of interference that may cause the equipment to respond to these interferences. Reduce the possibility by avoiding installation locations near high energy equipment.

General Product Information

The Merlin 1000BH is a gas pressure proving & gas detection controller for use in various applications. The system comprises a control panel and a gas pressure sensor.

The controller can receive connections from remote emergency shut-off buttons, two Merlin gas detectors, fire panel and heat detector. It also integrates with a BMS.

Access & Mounting

Unpack all the parts! Designed for surface mounting and must be installed by a licensed, insured contractor or competent person.

Carefully remove the front cover from the unit by unscrewing the four bolts located at each corner. To do this – use the socket wrench provided. Mark the four screw holes located on the back of the enclosure to the wall and ensure the wall surface is flat to prevent base distortion.

After executing the mounting and the connections – replace the front cover and insert the security caps over the four bolts.

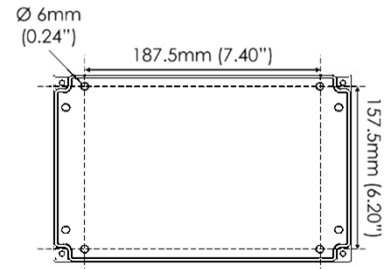

- ⚠ **Access to the interior, when carrying out any work, must be conducted by a competent person.**
- ⚠ **Before carrying out any work ensure local regulations and site procedures are followed.**
- ⚠ **We recommend all Merlin gas detection equipment and systems are commissioned by a competent/trained engineer to ensure correct installation and operation. Contact S&S Northern for more information.**

Electrical Connections

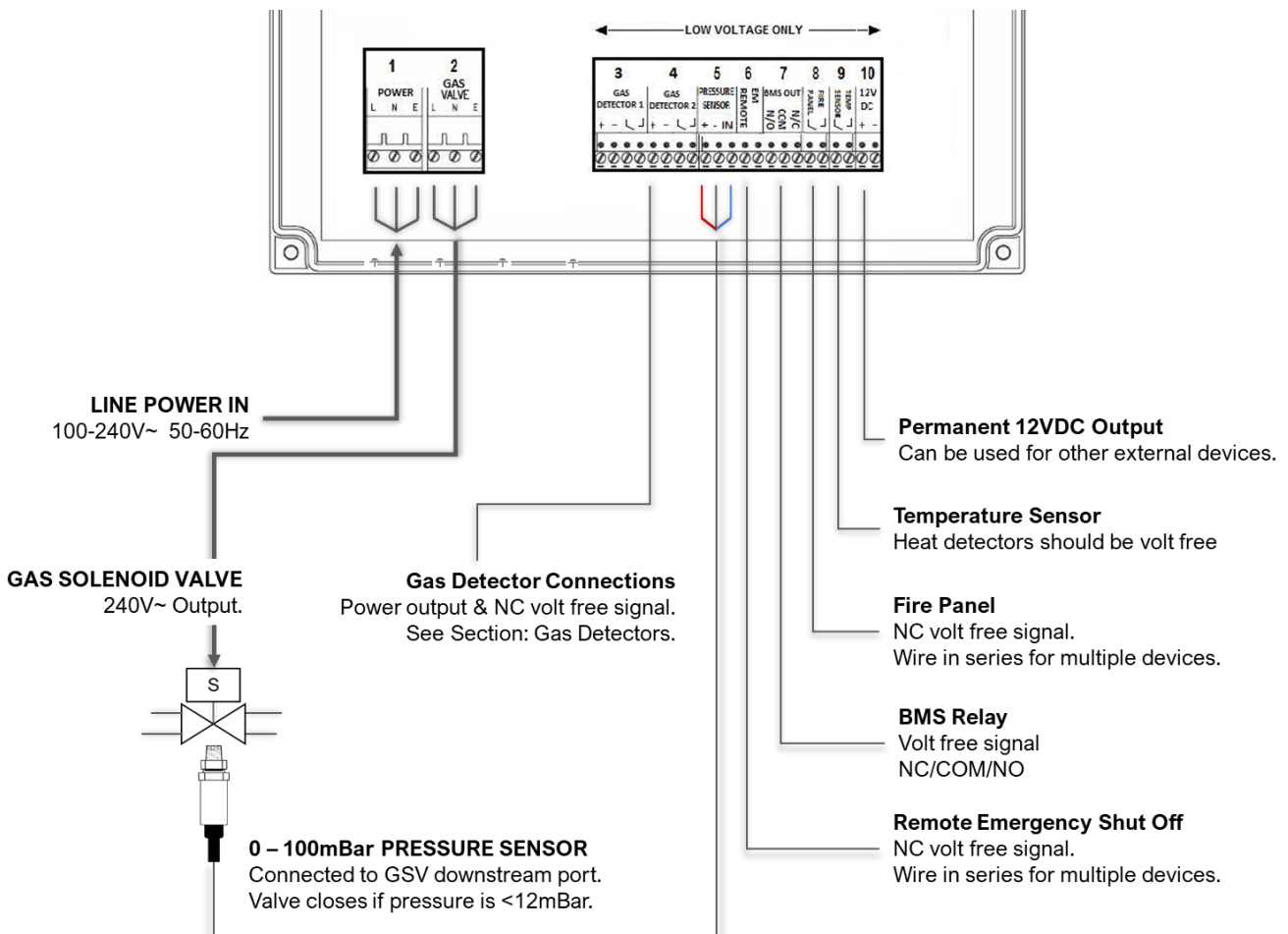

POWER

The Merlin 1000BH requires an ac single phase power supply rating of 100-240V~ connected to [Power In] terminal using a 3A fuse spur. Frequency 50-60Hz.

GAS VALVE

230V~ electrical power is supplied from the [GAS VALVE] connected to a solenoid valve which can shut the gas supply on alarm status. Refer to your valve manual for more information.

GAS DETECTOR 1 & 2

Refer to your gas detector manual for further information!

Connecting a Merlin Gas Detector

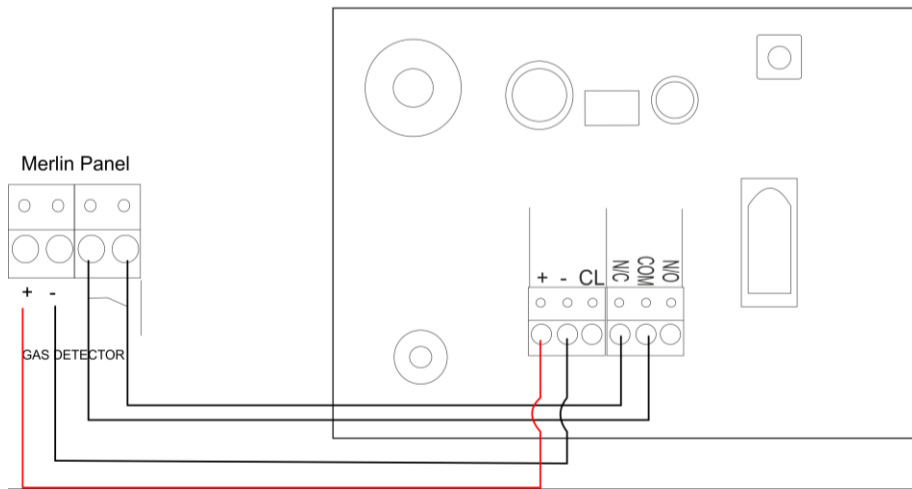

Connecting a Merlin Gas Detector i or Detector i-S

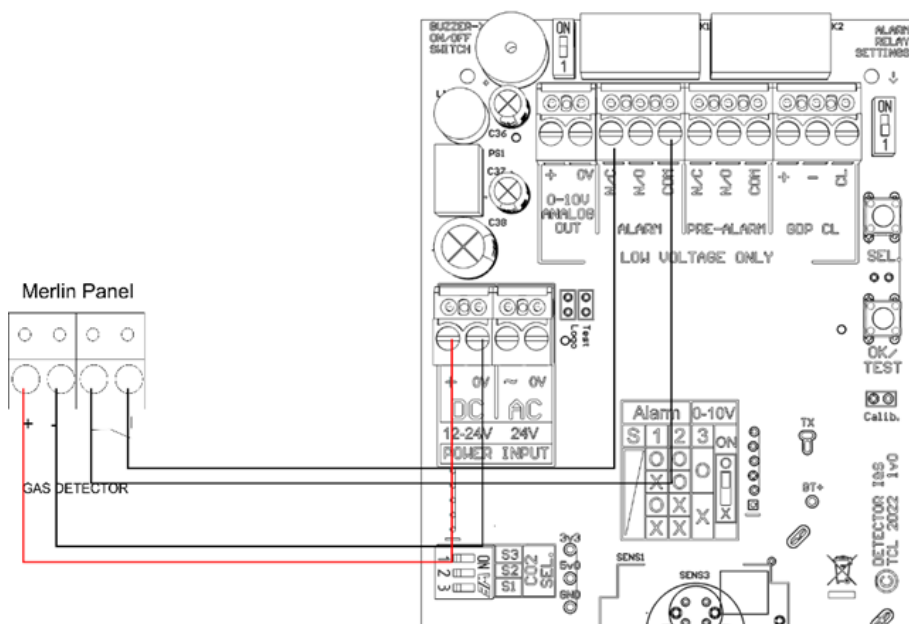

Connecting a Merlin Gas Detector X

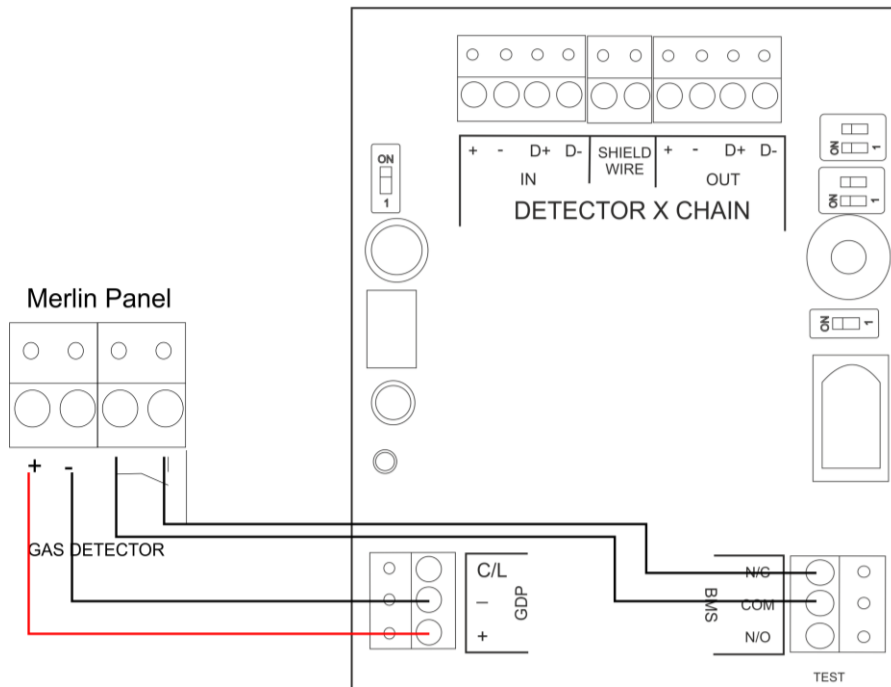

Connecting a Merlin CO2X

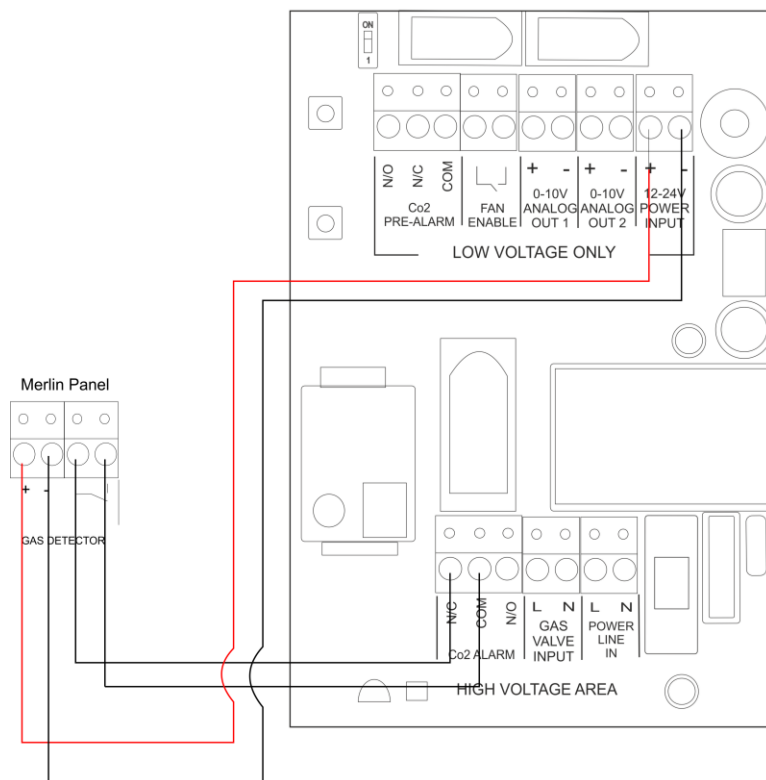

PRESSURE SENSOR

Connect the gas pressure transducer to these terminals and screw sensor to the downstream port on the solenoid valve.

Operating pressure: Min = 12mbar Max = 100mbar

Screw sensor into the downstream port of the solenoid valve!

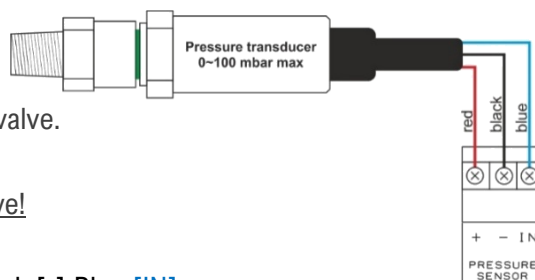

Connect the pressure sensor as shown: Wiring: Red **[+]** Black **[-]** Blue **[IN]**

EM REMOTE

Connections for remote emergency shut-off buttons or integrated with a fire alarm to close the gas supply automatically in the event of a fire. This is linked out as a factory setting.

Remote emergency shut-off buttons are volt free and wired to the terminal using a plenum security cable, white, 18/2 (18AWG 2 conductor), stranded, CMP or similar

BMS

Connections are available on the board for Building Management Systems.

[NO Normally Open] [COM Common] [NC Normally Closed]. These are volt free connections.

This is a relay that changes state when the gas is on/off and can be used in conjunction with the 12V DC output and other external relays that affect other devices and controls such as purge fans and audible alarms etc.

FIRE PANEL

The terminal for fire alarms is detailed on the circuit board as [FIRE PANEL]. These connections are linked out as a factory setting. Fire alarms should be volt free and wired to the Merlin 1000BH using two-core cable.

TEMP SENSOR

The terminal for heat detectors is detailed on the circuit board as [TEMP SENSOR].

These connections are linked out as a factory setting. Heat detectors should be volt free and wired to the Merlin 1000BH using two-core cable.

12VDC

This is a permanent 12v DC output when there is power at the panel. Normally used to power a PM2 current monitor. (Supplied separately)

Auto Reset Dipswitch

The panel has a built-in auto reset feature. There is a dipswitch located on the circuit board labelled [AUTO RESET]. This is factory set in the 'Off' position i.e. when power is restored after a power cut or loss, the panel must be restarted manually.

When enabled, the system will restart automatically when power is restored and can be reset following a fire alarm and when the alarm is cleared.

SWITCH	CONDITION
OFF	Panel must be restarted manually following a power cut/loss and/or alarm.
ON	Panel will automatically restart when power is restored and can be reset remotely via a fire panel.

BMS SEL Dipswitch

The panel can be integrated with a BMS to make or break a circuit on gas on/gas off, (valve open or valve closed). This will tell the BMS whether electrical power is being sent to the solenoid.

There is a dipswitch located on the circuit board labelled [BMS SEL]. This is factory set to 'OFF' position which signals the BMS on gas on/gas off.

When switched to 'ON' the system will only signal the BMS on a fault, i.e. gas detected, EM Stop pressed, etc.

SWITCH	BMS SIGNAL
OFF	Gas on or off only.
ON	Error condition i.e. gas detected, emergency stop pressed.

Fill & Prove Time Dipswitch

There are two switches located on the circuit board labelled [FILL TIME] and [PROVE TIME].

FILL TIME: Amount of time the gas valve opens to fill the gas line on power up or reset.

PROVE TIME: Amount of time the system tests the gas line for leaks on power up or reset.

FILL TIME		PROVE TIME	
OFF	5 Seconds (Default)	OFF	30 Seconds (Default)
ON	10 Seconds	ON	50 Seconds

Once the settings are changed - remove power for 10 seconds.

OPERATION

Initial Power Up

When the system is connected to the mains power supply, the Power LED will illuminate RED. Turn the key switch on to start the system.

The system will close the solenoid valve when an emergency stop is pressed, gas detected, or any alarm/fault signal is triggered.

Emergency Stop

The Emergency shut off button is located on the front of the panel. There is also a facility for remote shut off buttons to be installed (wired in series). The Emergency shut off button(s) will cut off the gas supply when activated. To reinstate the system, the Emergency shut off button(s) will need resetting, and the panel restarted.

LED Indications

- **GAS ON**

When the key switch is turned on, the Merlin 1000BH will check the installation for gas leaks. If gas proving is successful, the gas valve will open and the green 'Gas On' LED will illuminate.

ON = Gas Supply On / OFF = Gas Supply Off

- **TESTING**

This LED will illuminate GREEN for approximately 30 seconds when the panel is checking the integrity of the gas installation upon start up. **ON = proving the gas line, DO NOT operate any appliances.**

- **TEST FAIL**

Under normal working conditions this LED is off. When the panel detects a gas leak on start-up, the LED will illuminate AMBER. Gas valve will remain closed. **OFF = OK / ON = gas proving failed.**

- **PRESSURE LOW**

Under normal working conditions the LED is off. The LED will illuminate AMBER when pressure of the gas supply drops below 12mBar for 10 seconds the valve will close. **OFF = OK / ON = gas pressure low.**

- **GAS DETECTOR 1/2**

Under normal working condition this LED is off. If the external Merlin detector connected detects gas this will show RED and the Gas valve will turn off. **OFF = OK / ON = Gas detected.**

- **HEAT DETECTOR**

Under normal working condition this LED is off. If the temperature of the boilers reaches 72°C or higher (Heat detector required), the LED will show AMBER, and the Gas valve will turn off.

OFF = OK / ON = High temperature detected (72°C or higher)

- **EM STOP**

If an emergency shut off button (either remote or on the panel) is pressed, the LED will illuminate Amber, and the gas will be turned off. The EM Stop button must be re-set before restarting the system.

OFF = OK / ON = Emergency Stop button pressed.

- **FIRE ALARM PANEL**

If a fire alarm panel is triggered, the LED will illuminate Amber, and the gas will be turned off. The Fire alarm panel must be re-set before restarting the system. **OFF = OK / ON = Fire alarm panel triggered.**

MAINTAINENCE

Cleaning

Keep your system in good working order - follow these basic principles.

- Remove any dust/debris from the outer enclosures regularly using a slightly damp cloth.
- Never use detergents or solvents to clean your gs detection devices.
- Never spray air fresheners, hair spray, paint or other aerosols near the devices.
- Never paint devices. Paint will seal vents and interfere with the safety equipment.

SPECIFICATION

GENERAL	
Model:	1000BH
Size: (H x W x D)	7.08 x 10.03 x 3" (180 x 255 x 77 mm)
Housing Material:	ABS Polylac - PA765. UL 94 V-1
Mounting:	Indoor use - Wall Mounting
USER INTERFACE	
Visual Indicators:	LED
Audible Alarm:	>70dB @ 3.28ft (1m). Quiet conditions.
Language:	English
POWER SUPPLY	
Power Rating:	6W max.
Voltage Rating:	90-250V~ AC
Internal Fuse:	T3.15A L250V
EQUIPMENT	
Overvoltage Category:	II
Pollution Degree:	2
Equipment Class:	3
ENVIRONMENTAL	
Ingress Protection:	Not Formally Evaluated
Operating:	-10 ~ 50°C / 14 ~ 122°F 30 ~ 80% RH (non-condensing)
Storage:	-25 ~ 50°C / -13~122F° up to 95% RH (non-condensing)
Altitude Rating:	2000m
COMPLIANCE	
1000BH	CE / UKCA
Pressure Sensor	AS 4628/2005

Installation Details

Please pass this manual to the system owner / user.

Date of Installation:	
Installation Location:	
Organisation:	
Stamp/Signature of the installer:	

Every effort is made to ensure the accuracy of this document; however, S&S Northern can assume no responsibility for any errors or omissions in this document or their consequences. S&S Northern would greatly appreciate being informed of any errors or omissions that may be found in the content of this document. For information not covered in this document, or if there is a requirement to send comments/corrections, please contact S&S Northern using the contact details given below.

S&S Northern Head Office

Tel: +44(0) 1257 470 983

Fax: +44(0) 1257 471 937

www.snsnorthern.com

info@snsnorthern.com

Southeast Division

Tel: +44(0) 1702 291 725

Fax: +44(0) 1702 299 148

south@snsnorthern.com



S&S Northern is the owner of this document and reserves all rights of modification without prior notice.