

# MERLIN 1000VW+

Gas, Electric and Water Isolation Controller with Ventilation Interlocking



## INSTALLATION & OPERATION MANUAL

Please read these instructions carefully and retain for future use.

These instructions can be downloaded in electronic form on the product website ([www.snsnorthern.com](http://www.snsnorthern.com)) or a printed version can be ordered free of charge via S&S Northern Limited.



# Contents

<b>IMPORTANT INFORMATION .....</b>	<b>3</b>
Copyrights .....	3
Manufacturer's Warranty .....	3
Disposing of Electrical & Electronic Equipment (WEEE) .....	3
Revisions .....	3
Maintenance .....	3
Warning Symbol .....	4
<b>INSTALLATION .....</b>	<b>4</b>
General Safety Cautions.....	4
EMI and RF Interference Considerations.....	4
General Product Information.....	4
Access & Mounting.....	5
Electrical Connections.....	5
Auto Reset Dipswitch.....	10
BMS SEL Dipswitch .....	10
EM SEL Dipswitch (Fan Switch Integration).....	10
Fill & Prove Time Dipswitch .....	11
Automatic Shut Down Time Dipswitch.....	11
Auto Shut Down – Utility Selection .....	11
<b>OPERATION.....</b>	<b>11</b>
Initial Power Up .....	11
LED Indications.....	12
<b>MAINTENANCE .....</b>	<b>13</b>
Cleaning.....	13
<b>SPECIFICATION .....</b>	<b>16</b>

# IMPORTANT INFORMATION

## Copyrights

---

This manual is subject to copyright protection; all rights are reserved. Under international and domestic copyright laws, this manual may not be copied or translated, in whole or in part, in any manner or format, without the written permission of **S&S Northern Limited**

## Manufacturer's Warranty

---

The manufacturer warrants to the original consumer purchaser, that this product will be free of defects in material and workmanship for a period of **three (3) years**. The manufacturer's liability hereunder is limited to replacement of the product with repaired product at the discretion of the manufacturer. This warranty is void if the product has been damaged by accident, unreasonable use, neglect, tampering or other causes not arising from defects in material or workmanship. This warranty extends to the original consumer purchaser of the product only. Any implied warranties arising out of this sale, including but not limited to the implied warranties of description, merchantability and intended operational purpose, are limited in duration to the above warranty period. In no event shall the manufacturer be liable for loss of use of this product or for any indirect, special, incidental, or consequential damages, or costs, or expenses incurred by the consumer or any other user of this product, whether due to a breach of contract, negligence, strict liability in tort or otherwise. The manufacturer shall have no liability for any personal injury, property damage or any special, incidental, contingent, or consequential damage of any kind resulting from gas leakage, fire, or explosion. This warranty does not affect your statutory rights. During the above warranty period, your product will be replaced with a comparable product if the defective product is returned together with proof of purchase date. The replacement product will be in warranty for the remainder of the original warranty period or for six months – whichever is the greatest.

## Disposing of Electrical & Electronic Equipment (WEEE)

---

When this product has reached the end of its life it must be treated as Waste Electrical & Electronics Equipment (WEEE). Any WEEE marked products must not be mixed with general household waste, but kept separate for the treatment, recovery and recycling of the materials used. Please contact your supplier or local authority for details of recycling schemes in your area.



## Revisions

---

Every effort is made to ensure the accuracy of this document; however, **S&S** can assume no responsibility for any errors or omissions in this document or their consequences. **S&S** would greatly appreciate being informed of any errors or omissions that may be found in the content of this document. For information not covered in this document, or if there is a requirement to send comments/corrections, please contact **S&S** using the contact details given below.

## Maintenance

---

Gas Detection equipment must be inspected and serviced regularly by suitably qualified persons. Repair of the apparatus may only be carried out by trained service personnel.

## Warning Symbol

---

- ⚠ Where this symbol is used, consult manual to understand any potential hazards and how to avoid them.
- ⚠ **The information contained within this manual should be referenced for typical installation and operation only.**
- ⚠ **Isolate the equipment from all hazardous live power sources before opening the cover.**
- ⚠ **Any parts that form part of the connections/installation must have a minimum fire-retardant rating of UL 94 V-1.**
- ⚠ **For site specific requirements that may deviate from the information in this guide – contact your supplier.**
- ⚠ **If the equipment is used in a manner not specified, the safety provided by the equipment may be impaired.**
- ⚠ **This device is designed for indoor operation only.**
- ⚠ **Never ignore your device when in alarm.**
- ⚠ **This device requires a continual supply of electrical power – it will not work without power.**
- ⚠ **This device should not be used to substitute proper installation, use and/or maintenance of fuel burning appliances including appropriate ventilation and exhaust systems.**
- ⚠ **The device is not intended for use in potentially explosive atmospheres.**
- ⚠ **Your product should reach you in perfect condition, if you suspect it is damaged, contact your supplier.**

# INSTALLATION

## General Safety Cautions

---

Failure to observe the following may cause injury to persons and/or property.

Installation must be carried out by a licenced and insured contractor and installed in areas at risk of gas leaks and higher concentrated areas e.g., near boilers, valves, or areas of critical protection, located in positions determined by those who have knowledge of gas dispersion, the process plant system and equipment involved, and in consultation with both safety and electrical engineering personnel.

## EMI and RF Interference Considerations

---

All electronic devices are susceptible to EMI (Electromagnetic Interference) and RFI (Radio Frequency Interference). Our products are designed to reduce the effects of these interferences. However, there are still circumstances and levels of interference that may cause the equipment to respond to these interferences. Reduce the possibility by avoiding installation locations near high energy equipment.

## General Product Information

---

The Merlin 1000VW+ gas pressure proving, electric and water isolation system designed for use in educational buildings and laboratories with ventilation interlocking between the ventilation system and the gas solenoid valve. The system is compatible with both current monitors and air pressure differential switches to interlock with up to two fans.

This panel is to be used to carry out a gas proving test on the pipe work to highlight if there is a gas appliance open or a gas leak in the laboratory. The Merlin 1000VW+ is designed to give the teacher full control over the incoming gas and electric supply with the lockable main key-switch and touch sensors. The Merlin 1000VW+ can work in conjunction with Merlin gas detectors. The Merlin 1000VW+ also has a built in “timeout” facility which will automatically shut off the gas solenoid valve at the end of a specific time, this time can be adjusted to 2, 4, 8 hours or can be overridden if required.

## Access & Mounting

Unpack all the parts! Designed for surface mounting and must be installed by a licensed, insured contractor or competent person.

Carefully remove the front cover from the unit by unscrewing the four bolts located at each corner. To do this – use the socket wrench provided. Mark the four screw holes located on the back of the enclosure to the wall and ensure the wall surface is flat to prevent base distortion.

After executing the mounting and the connections – replace the front cover and insert the security caps over the four bolts.

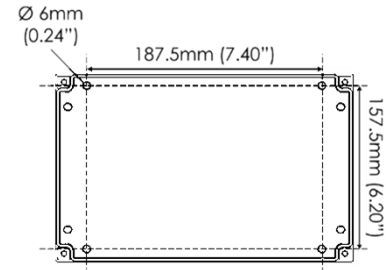

- ⚠ **Access to the interior of the panel, when carrying out any work, must be conducted by a competent person.**
- ⚠ **Before carrying out any work ensure local regulations and site procedures are followed.**
- ⚠ **We recommend all Merlin gas detection equipment and systems are commissioned by a competent/trained engineer to ensure correct installation and operation. Contact S&S Northern for more information.**

## Electrical Connections

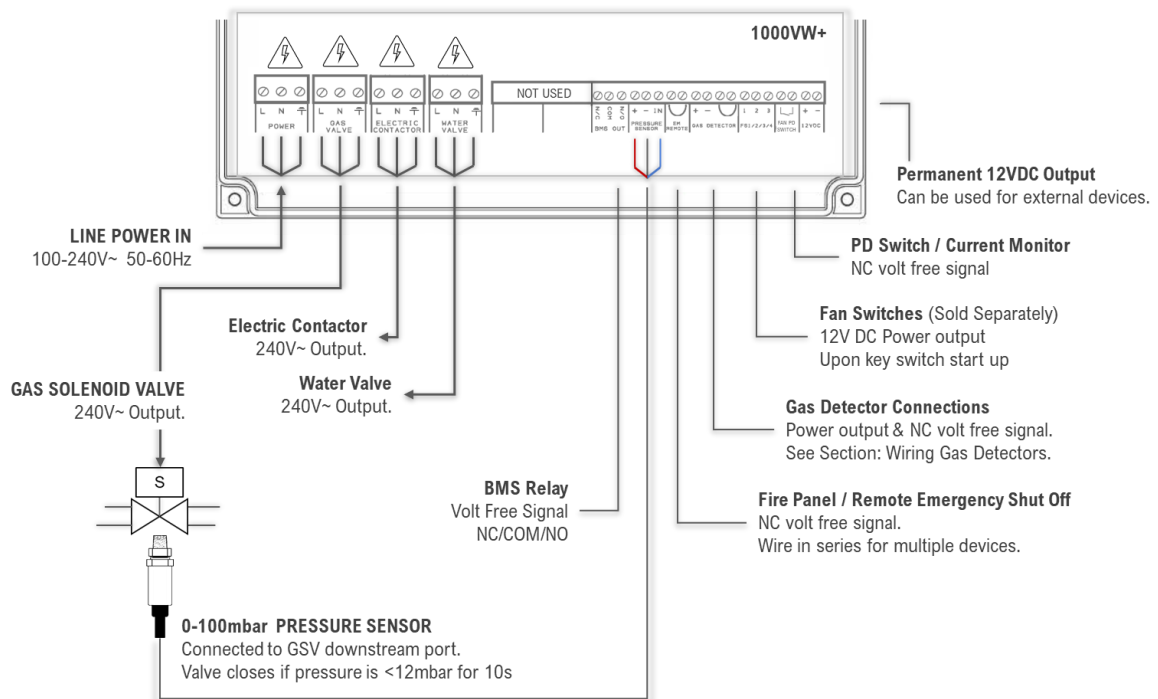

### POWER

The Merlin 1000V requires an ac single phase power supply rating of 100-240V~ connected to [Power In] terminal with a 3A fuse spur. When power is supplied a red LED will illuminate on the S&S logo.

## GAS VALVE

230V~ AC electrical power is supplied from the [GAS VALVE] connected to a solenoid valve which can shut the gas supply on alarm status. Refer to your valve manual for more information.

## ELECTRIC CONTACTOR

230V~ AC electrical power is supplied from the [ELECTRIC CONTACTOR] terminal connected to a contactor which can isolate electrics on alarm status. Refer to your contactor manual for more information.

## WATER VALVE

230V~ AC electrical power is supplied from the [WATER VALVE] terminal connected to a solenoid valve which can isolate water supply on alarm status. Refer to your contactor manual for more information.

## BMS

Connections are available on the board for Building Management Systems.

[NO Normally Open] [COM Common] [NC Normally Closed]. These are volt free connections.

This is a relay that changes state when the gas is on/off and can be used in conjunction with the 12V DC output and other external relays that affect other devices and controls such as purge fans and audible alarms etc.

## PRESSURE SENSOR

Connect the gas pressure transducer to these terminals and screw sensor to the downstream port on the solenoid valve.

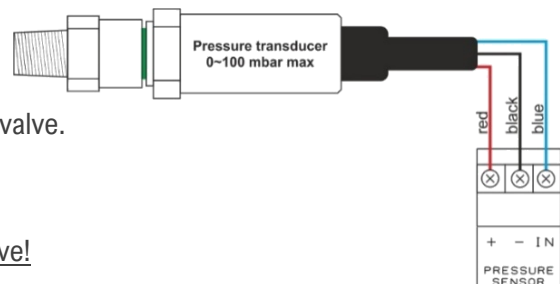

Operating pressure: Min = 12mbar Max = 100mbar

Screw sensor into the downstream port of the solenoid valve!

Connect the pressure sensor as shown: Wiring: Red **[+]** Black **[-]** Blue **[IN]**

## EM REMOTE

Connections for remote emergency shut-off buttons or integrated with a fire alarm to close the gas supply automatically in the event of a fire. This is linked out as a factory setting.

Remote emergency shut-off buttons are volt free and wired to the terminal using a plenum security cable, white, 18/2 (18AWG 2 conductor), stranded, CMP or similar

## GAS DETECTOR

Refer to your gas detector manual for further information!

### Connecting a Merlin Gas Detector

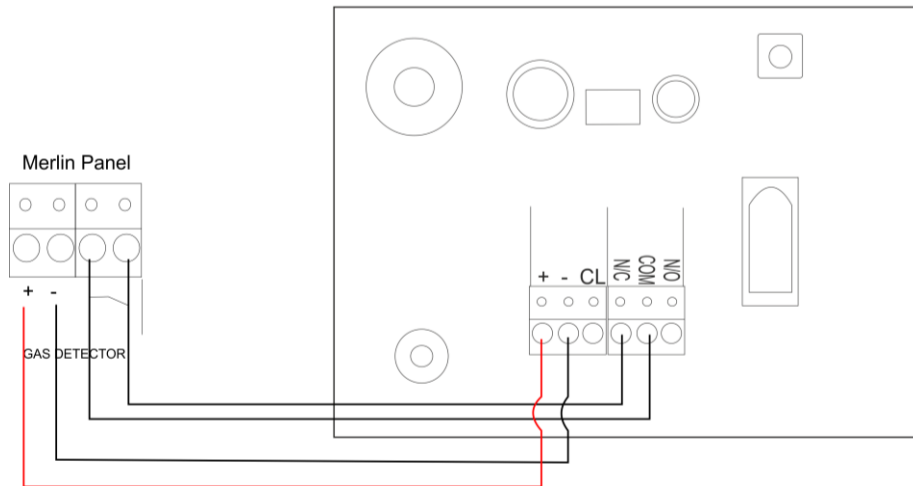

### Connecting a Merlin Gas Detector i or Detector i-S

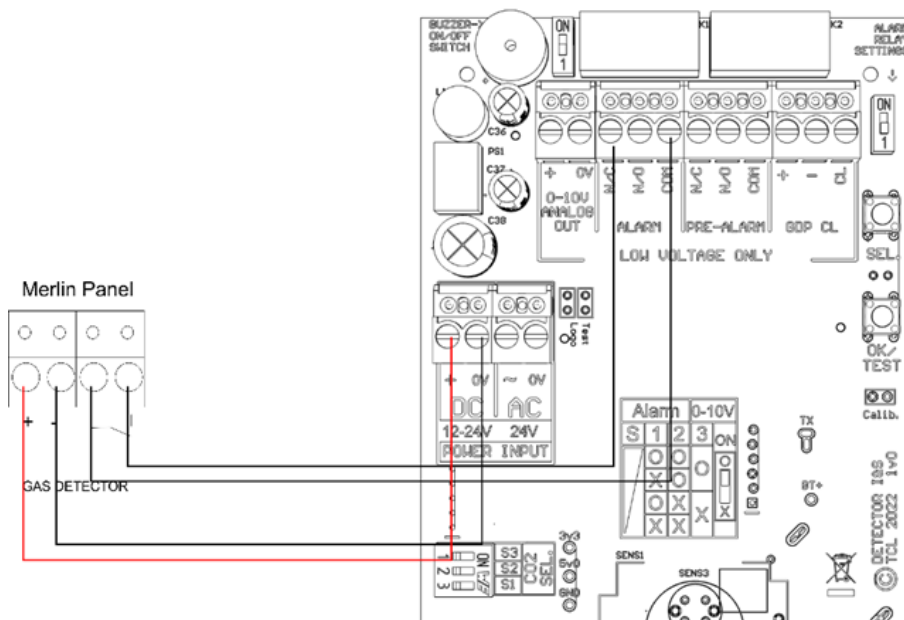

**Connecting a Merlin Gas Detector X**

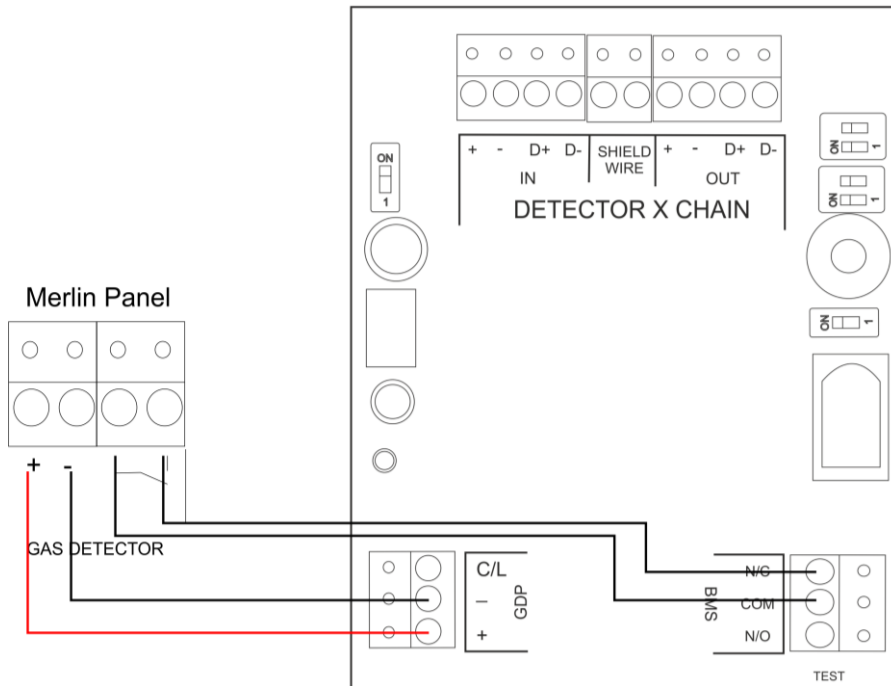

**Connecting a Merlin CO2X**

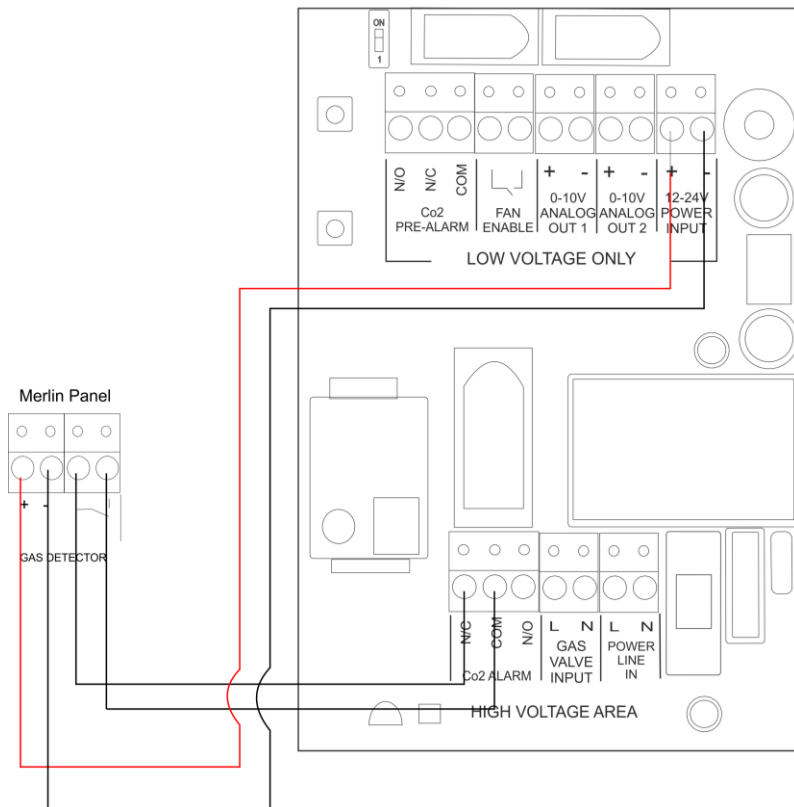



### FAN SWITCHES (FS 1 / 2 / 3)

These terminals can be connected to a fan switch (supplied separately) which provide power to fans when the emergency shut-off button is pressed. Example of a Merlin FS1 given.

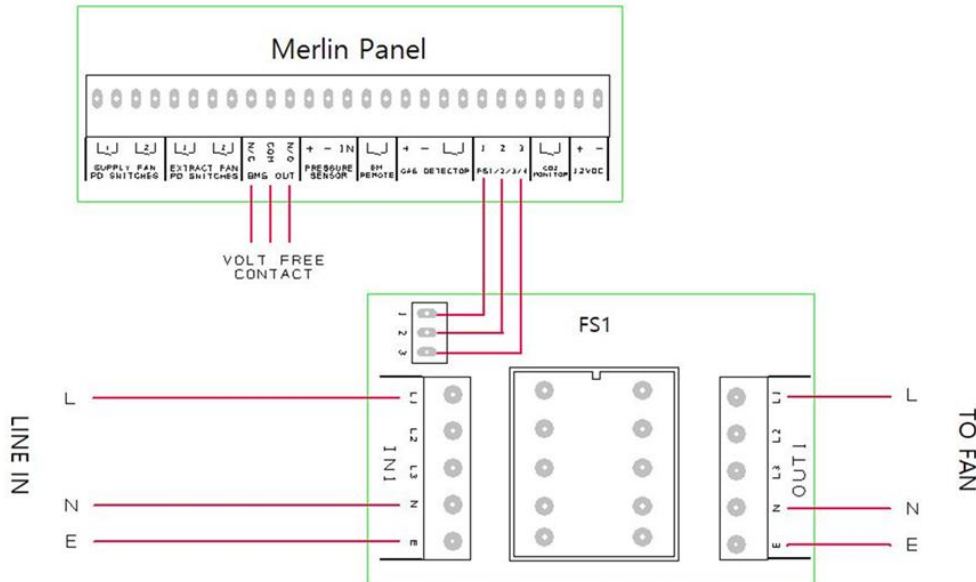

### PD SWITCHES & 12VDC

The PD terminals are used to receive an input signal from external air pressure switches or current monitors. This terminal is linked out as a factory setting.

Wiring to external air pressure switches or current monitors should be made using a two-core cable. This is a volt free connection

The 12VDC terminal is a permanent power output for external auxiliary devices when there is power at the panel and can be used to create a relay switch with the BMS relay output. Max output: 50mA

### PM2+ Example

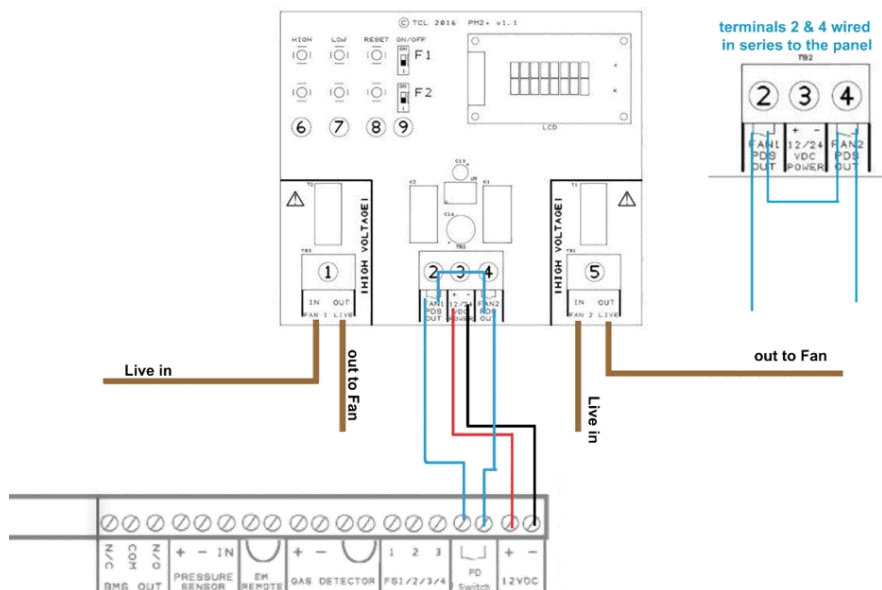

### Air Pressure Switch Diagram

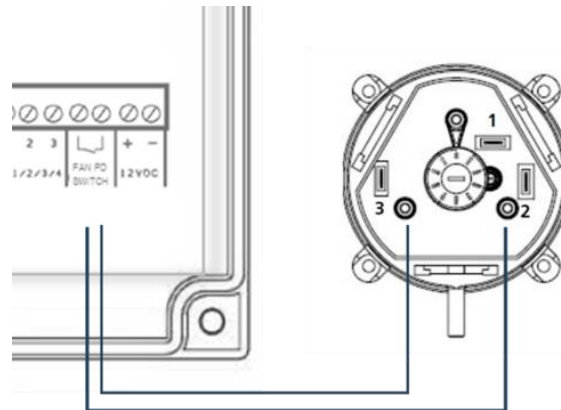

### Auto Reset Dipswitch

<b>OFF</b>	When power is restored after the power cut/ loss, the panel must be restarted manually. (Default)
<b>ON</b>	This will instruct the system to restart automatically when power is restored after power cut/loss.



### BMS SEL Dipswitch

<b>OFF</b>	Signals the BMS when gas supply is on, or gas is off. (Default)
<b>ON</b>	Signals the BMS on a fault i.e. high gas levels detected, emergency shut-off activated etc.



### EM SEL Dipswitch (Fan Switch Integration)

<b>OFF</b>	Instructs the system to shut down fan(s) and gas supply upon activation of emergency shut off button(s). (Default)
<b>ON</b>	Instructs the system to leave the fans on and shut off the gas supply only upon activation of emergency shut off button(s).



## Fill & Prove Time Dipswitch

**FILL TIME:** Amount of time the gas valve opens to fill the gas line on power up or reset.

**PROVE TIME:** Amount of time the system tests the gas line for leaks on power up or reset.

Fill Time		Prove Time	
OFF	5 Seconds (Default)	OFF	30 Seconds (Default)
ON	10 Seconds	ON	50 Seconds

Once the settings are changed - remove power for 10 seconds.



## Automatic Shut Down Time Dipswitch

The system has an auto-shut down feature after a selected time which will isolate the gas supply.

There are two switches located on the circuit board labelled [TIME1] & [TIME2].

These can be configured to select the required timeout/ shut-down period.

TIME 1	TIME 2	Timeout Period
OFF	OFF	2 Hours (Default)
ON	OFF	4 Hours
OFF	ON	8 Hours
ON	ON	Disabled



## Auto Shut Down – Utility Selection

There is a switch located on the circuit board labelled [ELECTR] and [WATER].

This is factory set to 'Off'.

When switched On - This will instruct the system to also turn off Electrical and water supply when performing auto-shut down.



# OPERATION

## Initial Power Up

Upon supplying mains power – the red LED will illuminate on the S&S logo. Turn the key switch to on position. The Gas, Electric & Water LEDs will flash blue for 10 seconds.

Press the relevant touch button to activate gas, electric and/or water utility.

**All services can be turned on or off within 10 seconds of the key switch being turned on. After 10 seconds, utility buttons are disabled. Turn the key off and back on to adjust any services.**

## LED Indications

---

### ● GAS

When gas service is turned on, the gas LED will illuminate blue, and the system will start testing the gas line. **ON = Gas on / FLASHING = Gas Off, Gas button enabled / OFF = Gas Off, Gas button disabled.**

### ● ELECTRIC

When electric service is turned on, the Electric LED will illuminate blue and 230V~ will be sent from the terminal. **ON = Electric on / FLASHING = Electric Off, button enabled / OFF = Electric Off, button disabled.**

### ● WATER

When water service is turned on, the water LED will illuminate blue and 230V~ will be sent from the terminal. **ON = Water on / FLASHING = Water Off, button enabled / OFF = Water Off, button disabled**

### ● TESTING

This LED will illuminate GREEN for approximately 30 seconds when the panel is checking the integrity of the gas installation upon start up. **ON = proving the gas line, do NOT operate any appliances.**

### ● TEST FAIL

When the panel detects a gas leak on start-up, the LED will illuminate AMBER. Gas valve will remain closed. **OFF = OK / ON = gas proving failed.**

### ● PRESSURE LOW

The LED will illuminate AMBER when pressure of the gas supply drops below 12mbar for 10 secs. The gas valve will close. **OFF = OK / ON = gas supply pressure low.**

### ● TIMEOUT

This LED will illuminate AMBER when auto-shut down has occurred. **OFF = OK / ON = Auto-shut down activated**

### ● EM STOP

If an emergency shut off button (either remote or on the panel) is pressed, the LED will illuminate AMBER, and the gas will be turned off and the fans switch (if a fan switch is connected). **OFF = OK / ON = Emergency Shut-Off button activated.**

### ● CO2 / GAS DETECTED

If the external Merlin detector connected detects gas this will show RED, and the gas valve will turn off. **OFF = OK / ON = Gas detected.**

### ● FAN FAULT

If a fan fault is detected for longer than 10 seconds the LED will illuminate red, and the gas valve will close. **OFF = OK / ON = Gas supply isolated due to a ventilation fault.**

# MAINTENANCE

## Cleaning

---

Keep your panel in good working order - follow these basic principles.

- Remove any dust/debris from the outer enclosure regularly using a slightly damp cloth.
- Never use detergents or solvents to clean your device.
- Never paint the device. Paint will seal vents and interfere with the device.

Page intentionally left blank

Page intentionally left blank

# SPECIFICATION

General	
Model:	1000VW+
Size: (H x W x D)	7.08 x 10.03 x 3" (180 x 255 x 77 mm)
Housing Material:	ABS Polylac - PA765. UL 94 V-1
Mounting:	Indoor use - Wall Mounting
User Interface	
Visual Indicators:	LED
Audible Alarm:	>70dB @ 3.28ft (1m). Quiet conditions.
Language:	English
Power Supply	
Power Rating:	6W max.
Voltage Rating:	100-120V~ 50-60Hz
Internal Fuse:	T3.15A L250V
Equipment	
Overvoltage Category:	II
Pollution Degree:	2
Equipment Class:	2
Environmental	
Ingress Protection:	Not Formally Evaluated
Operating:	-10 ~ 50°C / 14 ~ 122°F 30 ~ 80% RH (non-condensing)
Storage:	-25 ~ 50°C / -13~122F° up to 95% RH (non-condensing)
Altitude Rating:	2000m
Approvals	
Electromagnetic Compatibility and Electrical Safety	IEC 61010-1:2010 + AMD1:2016; EMC EN 61326-1:2013



Every effort is made to ensure the accuracy of this document; however, S&S Northern can assume no responsibility for any errors or omissions in this document or their consequences. S&S Northern would greatly appreciate being informed of any errors or omissions that may be found in the content of this document. For information not covered in this document, or if there is a requirement to send comments/corrections, please contact S&S Northern using the contact details given below.

**S&S Northern Head Office**

Tel: +44(0) 1257 470 983

[www.snsnorthern.com](http://www.snsnorthern.com)[info@snsnorthern.com](mailto:info@snsnorthern.com)**Southeast Division**

Tel: +44(0) 1702 291 725

[south@snsnorthern.com](mailto:south@snsnorthern.com)

S&S Northern is the owner of this document and reserves all rights of modification without prior notice.