

## BK-G40, BK-G65, BK-G100

BK-G40T, BK-G65T, BK-G100T  
Industrial diaphragm gas meters

### Applications

Media: Natural gas, city gas, propane, butane, inert gases  
Branches: Gas industry  
Tasks: Measuring of the actual volume

### Brief information

The metering gear of the BK-G40, BK-G65 and BK-G100 industrial diaphragm meters consists of up to 8 measuring units (depending on the size of the meter) operating in parallel. Each of the measuring units contains 4 measuring chambers, separated from each other by synthetic diaphragms. The chambers are periodically filled and emptied. A gear transmits the movement of the diaphragm to the corresponding crankshaft. The shaft then drives the valves which control the gas flow. The revolutions of the gear are transmitted via a magnetic coupling to the index.

Honeywell industrial diaphragm meters are compact and have a perfect weight ratio. They meet the highest standards in terms of metering accuracy and safety. The BK series of industrial diaphragm meters combines innovative new developments with decades of Honeywell experience. The meters come with a deep-drawn, screwed, or welded, steel housing and can be supplied either with co-axial or twin-pipe connections.

The gas meters can be equipped with different index solutions.

The measuring units in the industrial diaphragm meters operate in line with the principle of pneumatic control, meaning less force is exerted on the bearings, which results in low-noise operation.

The well-proven and patented K-System for adjusting and synchronising the measuring units together with the use of high-grade materials guarantees a high degree of quality and metering accuracy.

The use of small valves ensures that the industrial diaphragm meters are  $Q_{\min}$  stable and are not susceptible to dirt or any other contamination.

The new generation of industrial diaphragm meters are extremely robust but should, nevertheless, be handled with the same care that every metering device deserves.

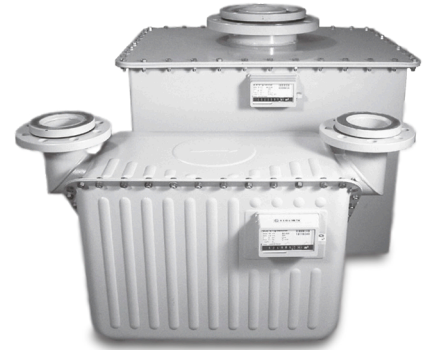

### Main features

- MID conformity approved by PTB
- EC-approved by German PTB for flow rates from 0.40 m<sup>3</sup>/h to 160 m<sup>3</sup>/h
- Approved to EN 1359 by German DVGW
- Cyclic volume:  
BK-G40: 18 litres, BK-G40T: 16.8 litres  
BK-G65: 24 litres, BK-G65T: 22.4 litres  
BK-G100: 48 litres, BK-G100T: 44.8 litres
- Maximum operating pressure 0.5 bar (0.1 bar for fireproof applications to EN 1359)
- High accuracy and long term reliability
- Powder coated pale grey to RAL 7035
- Pulse magnet as standard;  
a LF-pulsar can be added at any time  
BK-G40/G65: I = 0.1 m<sup>3</sup>/pulse  
BK-G100 standard: I = 1.0 m<sup>3</sup>/pulse  
BK-G100 with S1 index: I = 0.1 m<sup>3</sup>/pulse
- Low noise level
- Not susceptible to contamination (RPF=0.8)
- Gas temperature: -10 °C to +40 °C  
other temperatures on request
- Mechanical temperature compensation (option)
- Compact and handy design
- Reverse flow valve (option)

# BK-G40 and BK-G65

## Dimensions and weights

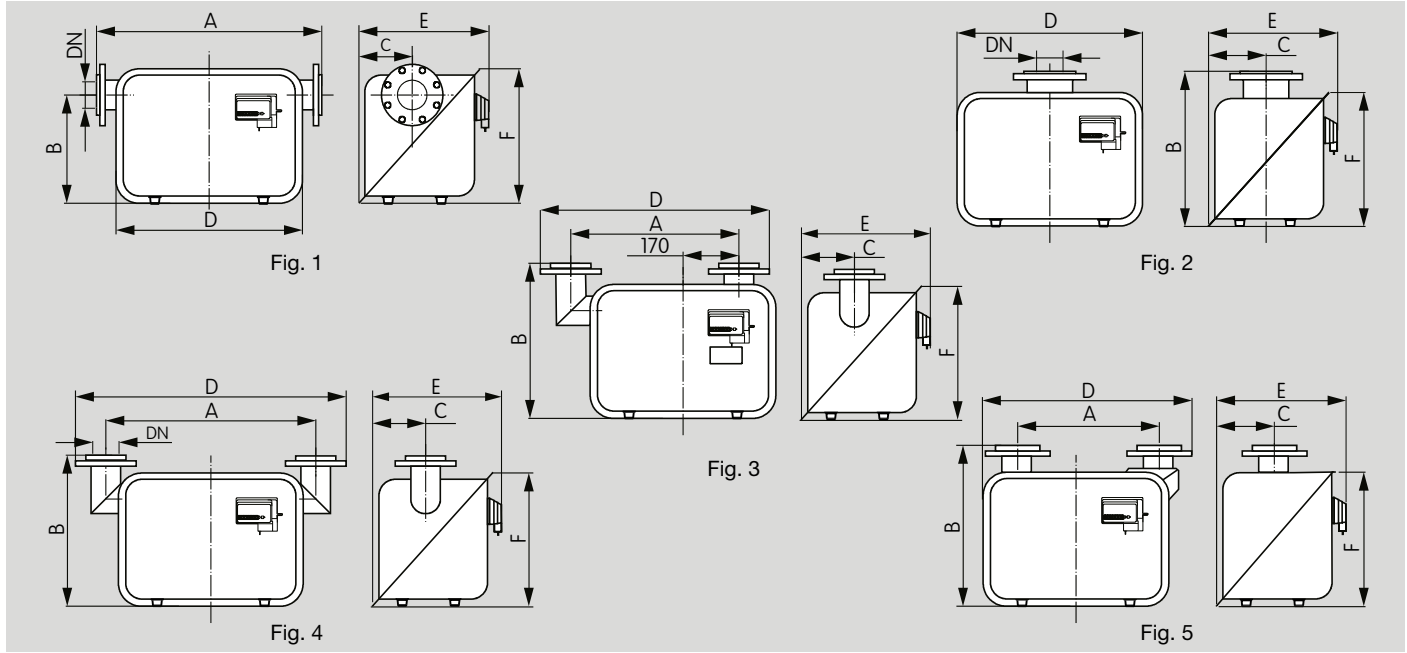
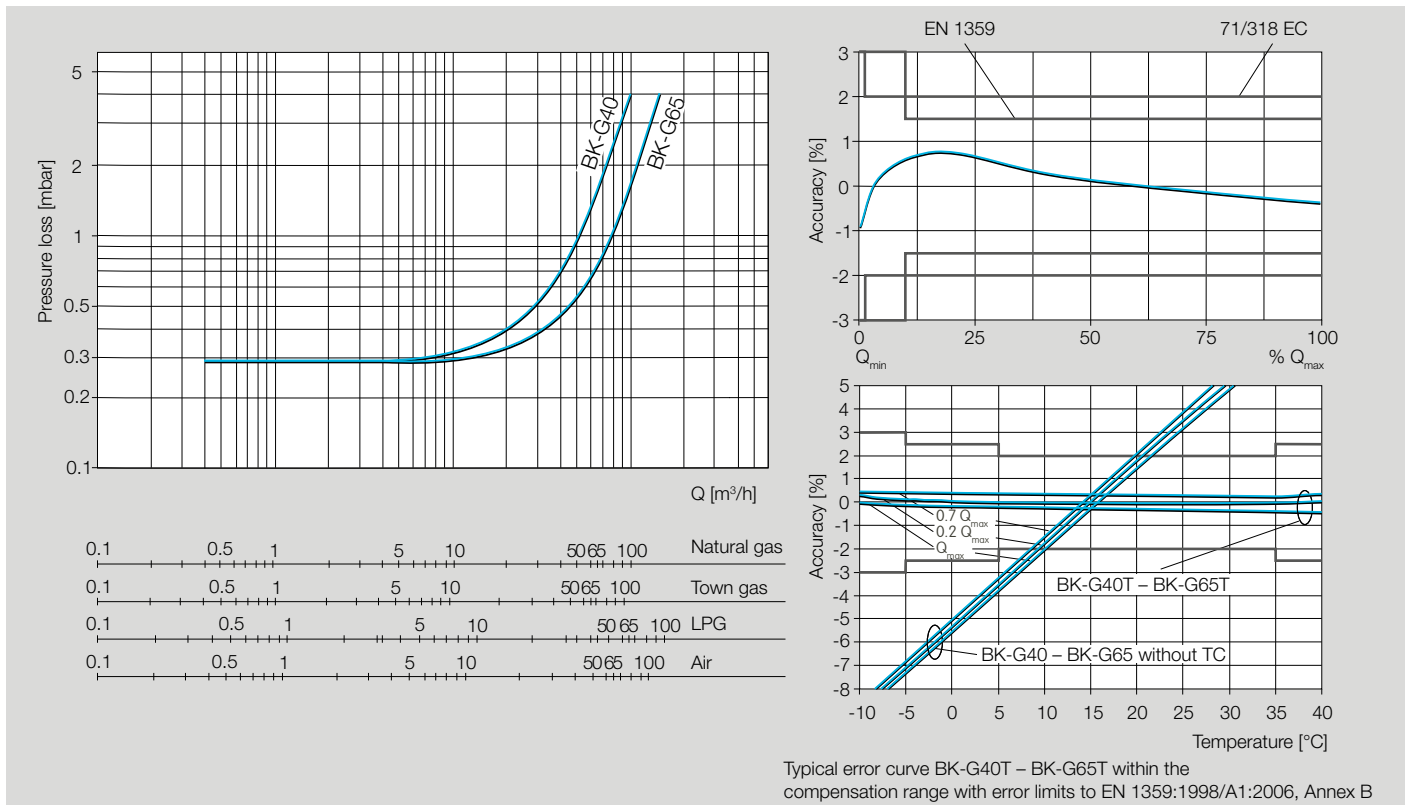

Fig.	Type	Q <sub>max</sub> [m <sup>3</sup> /h]	Q <sub>min</sub> [m <sup>3</sup> /h]	V [dm <sup>3</sup> ]	Mounting flange***		Dimensions [mm]						Weight [kg]
					Standard	Optional	A****	B	C	D	E	F	
1	BK-G40	65	0.40	18	DN80	DN65	570	337	161	564	392	413	28
2	BK-G40	65	0.40	18	DN80**	DN65**	-	480	175	564	392	413	26
3	BK-G40	65	0.40	18	DN80	DN65	510	480	175	710*	392	413	29
5	BK-G40	65	0.40	18	DN65	-	335	480	175	520	392	413	28
1	BK-G65	100	0.65	24	DN80	DN100	680	337	161	564	392	413	29
2	BK-G65	100	0.65	24	DN80**	-	-	480	175	564	392	413	28
3	BK-G65	65	0.65	24	DN80	-	500	480	175	712	392	413	29
4	BK-G65	100	0.65	24	DN80	DN100	640	470	161	840*	392	413	32
5	BK-G65	100	0.65	24	DN80	-	430	498	175	632	392	413	30

\*for DN80, \*\*according to DIN 3376, \*\*\*flanges according to DIN 2642, PN10, \*\*\*\*other dimensions on request

## Typical pressure loss and error curve



Typical error curve BK-G40T – BK-G65T within the compensation range with error limits to EN 1359:1998/A1:2006, Annex B

# BK-G100

## Dimensions and weights

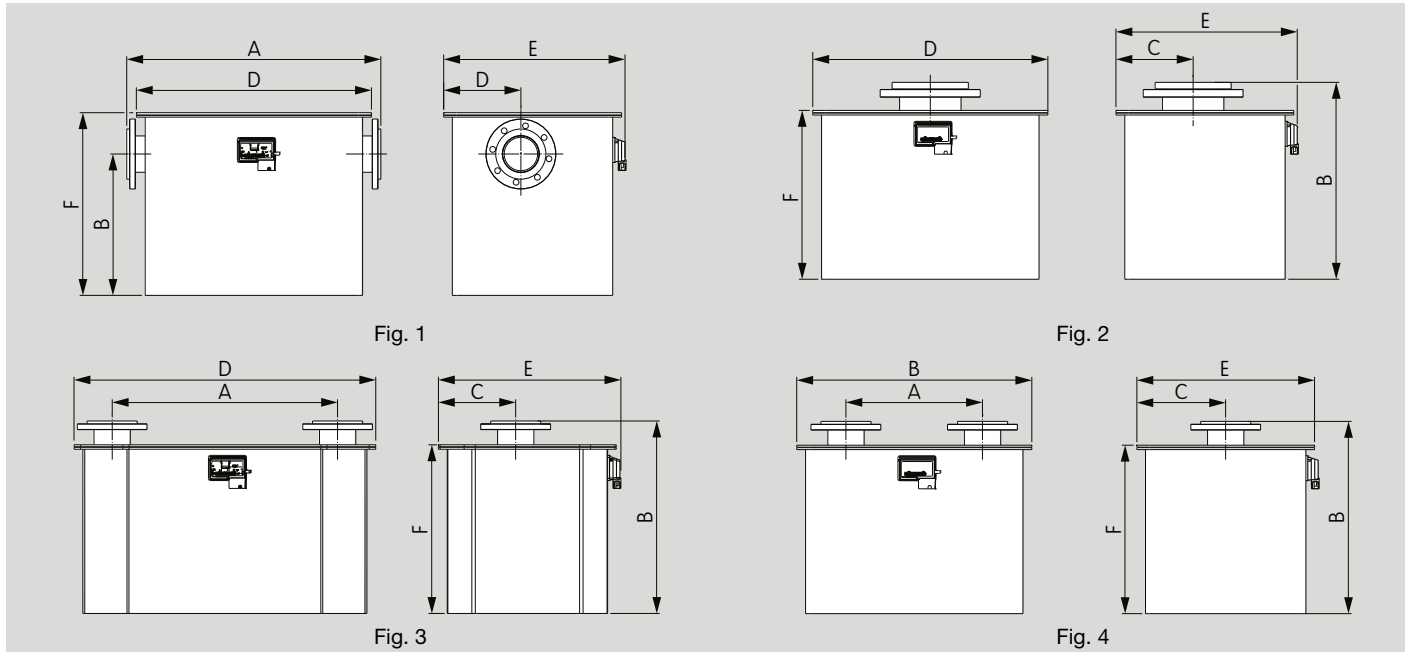
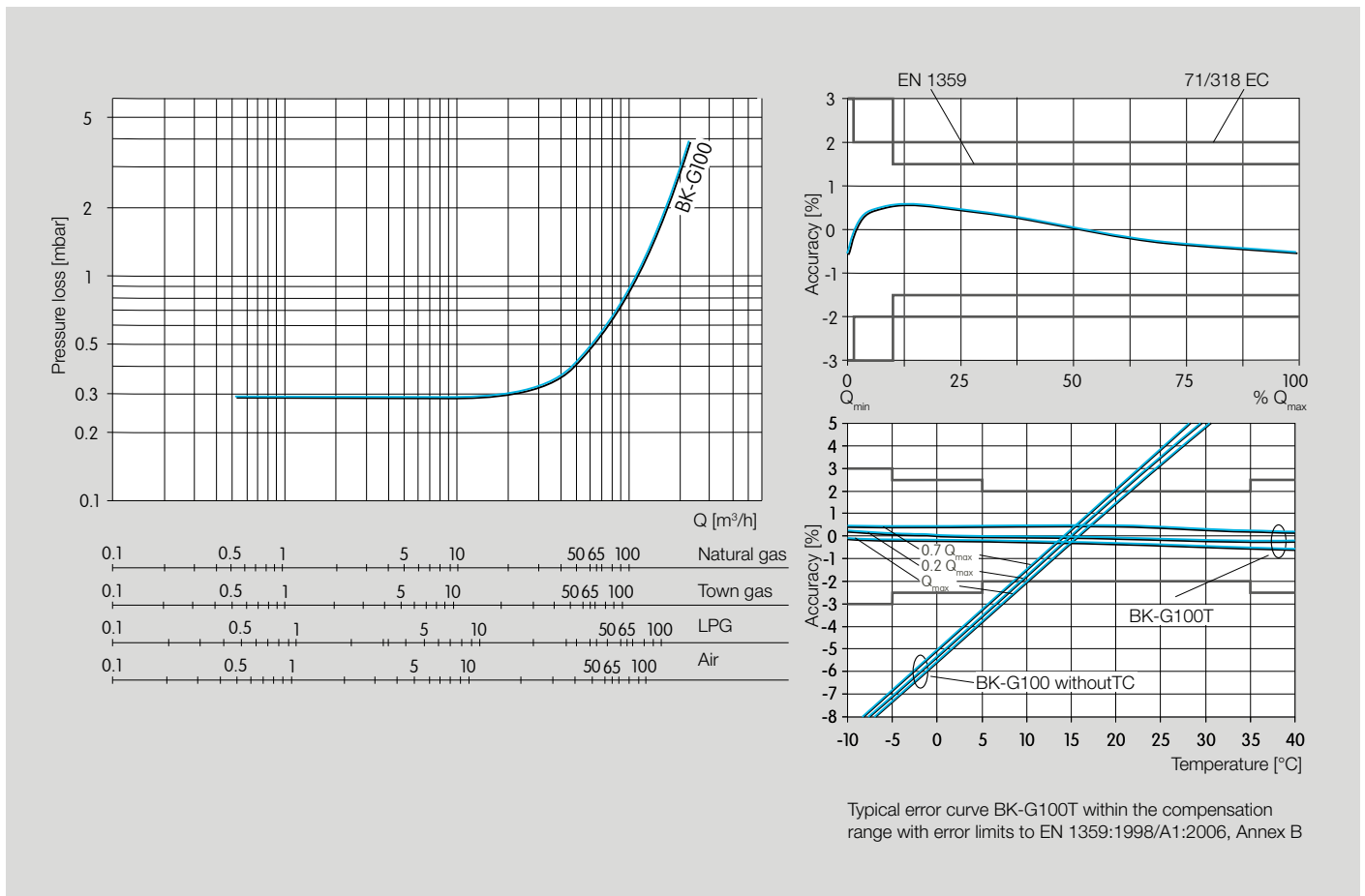

Fig.	Type	Q <sub>max</sub> [m <sup>3</sup> /h]	Q <sub>min</sub> [m <sup>3</sup> /h]	V [dm <sup>3</sup> ]	Mounting flange	Dimensions [mm]						Weight [kg]	
						A	B	C	D	E*	E**		F
1	BK-G100	160	1	48	DN100	800	448	243	740	571	606	577	95
2	BK-G100	160	1	48	DN100	-	621	243	740	571	606	533	100
3	BK-G100	160	1	48	DN100	710	608	243	950	571	606	533	105
3	BK-G100	100	1	48	DN100	675	608	243	950	571	606	535	105
4	BK-G100	160	1	48	DN100	430	608	280	740	571	606	533	95

\*standard, \*\*with S1 index

## Typical pressure loss and error curve



## Versions

BK-G40/BK-G65



BK-G100

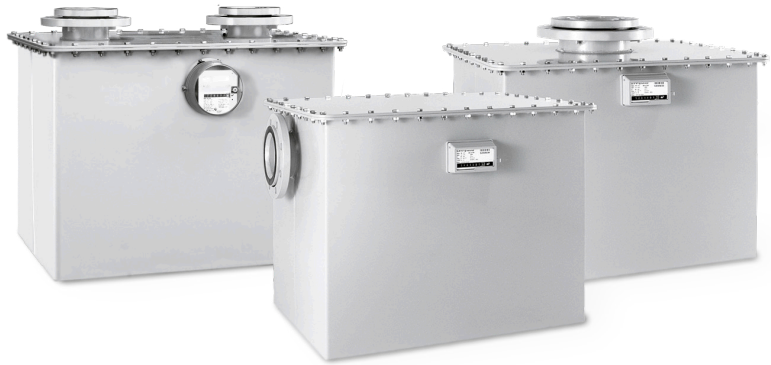

## Industrial gas meter with Absolute ENCODER technology (option)



### Transferred data:

- Meter reading
- Meter type
- Serial number
- Media
- Manufacturing date



Schematic representation of transferring the original meter reading via SCR interface to a data logger DL210.  
The Absolute ENCODER index is available with the M-BUS and SCR interface variants.