

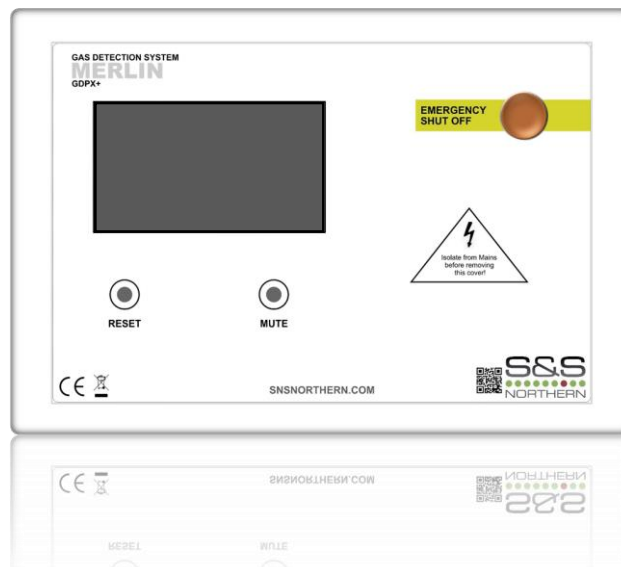

MERLIN GDPX+

Addressable Safe Area Gas Detector-X Controller



Installation, Operation & Maintenance

Please read this manual carefully and retain for future use.

S&S Northern provide a range of detection panels which can be used in many applications such as factories, car parks, shopping centres and boiler houses. The GDPX+ can be used with up to sixteen (16) X range gas detectors in a single cable run for monitoring and detecting gas in zones considered safe including CO, LPG and methane.

- ⚠ The information contained within this manual should be referenced for typical installation and operation only.
- ⚠ For specific requirements that may deviate from the information in this guide – contact your supplier.

Contents

Important Warning Statements	3
Installation	4
Typical Application, Location & Positioning	4
Access & Mounting	5
Internal Board Overview	5
Board Connections Overview	6
Wiring your Detector	7
Creating a Detector Chain	7
Detector ID Switches	8
120ohm Termination Resistance – Detector Chains	8
BMS MODBUS	9
120ohm Termination Resistance – BMS MODBUS	9
MODBUS Data Settings	9
Configuration Settings	10
Settings Options Explained	10
Factory Set Condition	11
Trouble Shooting	11
Operation	12
First Power Up (Commissioning)	12
Main Screen	12
Zone Status	12
Zone Screens	12
Diagnostic Screen	13
Alarm Messages	13
General Maintenance	14
Cleaning	14
Manual Circuit Simulation Test	14
Service Reminders	14
Bump Test (Gas Response Check)	14
Standard Test Gases	15
Bump Test Procedure	15
Reset Service Message	16
End of Operational Life (EOL)	16
Specification	19



Important Warning Statements

Please take the time to thoroughly read these instructions which should be retained for future reference.

Detectors are shipped pre-calibrated and configured.

The expected lifetime of a gas sensor is 3-10 years upon initial power up dependant on your target gas and environmental factors. The device will display a message to indicate this time and should immediately be replaced.

It is recommended that this device be commissioned upon installation and serviced annually by a competent person.

Do not apply lighter gas or other aerosols to the device – this will cause extreme damage to the sensors.

High concentrations of alcohol found in many products may damage, deteriorate or affect the gas sensing elements.

This device is designed to detect the gas type displayed on the screen only.

It is not designed to detect smoke, fire or other gases and should not be used as such.

This device provides early warning of the presence of gas, usually before a healthy adult would experience symptoms. This warning is possible provided your alarm is installed and maintained in accordance with this manual.

Never ignore your device when in alarm.

This device requires a continual supply of electrical power – it will not work without power.

This device should not be used to substitute proper installation, use and/or maintenance of fuel burning appliances including appropriate ventilation and exhaust systems.

Multiple detectors may be required to adequately protect property and persons.

This device does not prevent dangerous gasses from occurring or accumulating.

Actuation of your alarm indicates the presence of dangerous levels of gas.

The device is not intended for use in potentially explosive atmospheres.

Seek fresh air supply and contact your local gas emergency service should you suspect a gas leak.

This unit may not fully safeguard individuals with specific medical conditions. If in doubt, consult a doctor/physician.

Your product should reach you in perfect condition, if you suspect it is damaged, contact your supplier.

Manufacturer's Warranty

Warranty coverage: The manufacturer warrants to the original consumer purchaser, that this product will be free of defects in material and workmanship for a period of three (3) years from date of purchase or one (1) years for oxygen detectors.

The manufacturer's liability hereunder is limited to replacement of the product with repaired product at the discretion of the manufacturer. This warranty is void if the product has been damaged by accident, unreasonable use, neglect, tampering or other causes not arising from defects in material or workmanship. This warranty extends to the original consumer purchaser of the product only. **Warranty disclaimers:** Any implied warranties arising out of this sale, including but not limited to the implied warranties of description, merchantability and intended operational purpose, are limited in duration to the above warranty period. In no event shall the manufacturer be liable for loss of use of this product or for any indirect, special, incidental or consequential damages, or costs, or expenses incurred by the consumer or any other user of this product, whether due to a breach of contract, negligence, strict liability in tort or otherwise. The manufacturer shall have no liability for any personal injury, property damage or any special, incidental, contingent or consequential damage of any kind resulting from gas leakage, fire or explosion. This warranty does not affect your statutory rights. **Warranty Performance:** During the above warranty period, your product will be replaced with a comparable product if the defective product is returned together with proof of purchase date. The replacement product will be in warranty for the remainder of the original warranty period or for six months – whichever is the greatest.

Information on waste disposal for consumers of electrical & electronic equipment.



When this product has reached the end of its life it must be treated as Waste Electrical & Electronics Equipment (WEEE). Any WEEE marked products must not be mixed with general household waste, but kept separate for the treatment, recovery and recycling of the materials used. Please contact your supplier or local authority for details of recycling schemes in your area.

At the end of their working life, electrochemical sensors for oxygen and carbon monoxide detectors should be disposed of in an environmentally safe manner. Alternatively they can be securely packaged and returned to S&S Northern clearly marked for disposal. Electrochemical sensors should not be incinerated as this may cause the cell to emit toxic fumes.

Installation

Typical Application, Location & Positioning

The Merlin GDPX+ is a multi-safe zone gas detection panel which can be used in many applications such as factories, car parks, shopping centres and most commonly - boiler houses. It can be used with up to sixteen Merlin gas detectors (model X) for monitoring and detecting gas including carbon monoxide, liquid petroleum gas and methane. The controller panel can be integrated with, but not limited to, a BMS (building management system) including MODBUS, a fire panel, external alarms and remote emergency shut-off buttons.

Locations for detectors will vary based on the intended application and target gas, they should be located near identified sources of a potential gas leaks/ pockets where hazardous gas could quickly accumulate and areas of identified consequential risk. The composition of the target gas and its density relative to air are used as the basis for any recommended height of detector placement. Generally, the installation height of a detector for a heavy gas (such as propane) would be close to the lowest point in the area, and for a light gas (such as methane) would be close to the highest point in the area. Any recommended heights may vary based on air flow and temperature conditions in addition to the proposed application and location – this is particularly apparent with oxygen depletion sensors, and the target gas that they are used for.

Target Gas

- Natural Gas/Methane (NG)
- Liquid Petroleum Gas (LPG)
- Carbon Monoxide (CO)
- Hydrogen (H)
- Oxygen (O₂)

Typical Position

- High Level - 300mm (1ft) from ceiling
- Low Level - 300mm (1ft) from ground level
- Breathing Zone - 1700mm (5ft 6") from ground level
- High Level - 300mm (1ft) from ceiling
- *Breathing Zone - 1000-1500mm (3 - 5ft) from ground level

* If you are installing and monitoring Oxygen depletion – consider the density of gas for its application and position the detector accordingly i.e. ground level for high density gases.

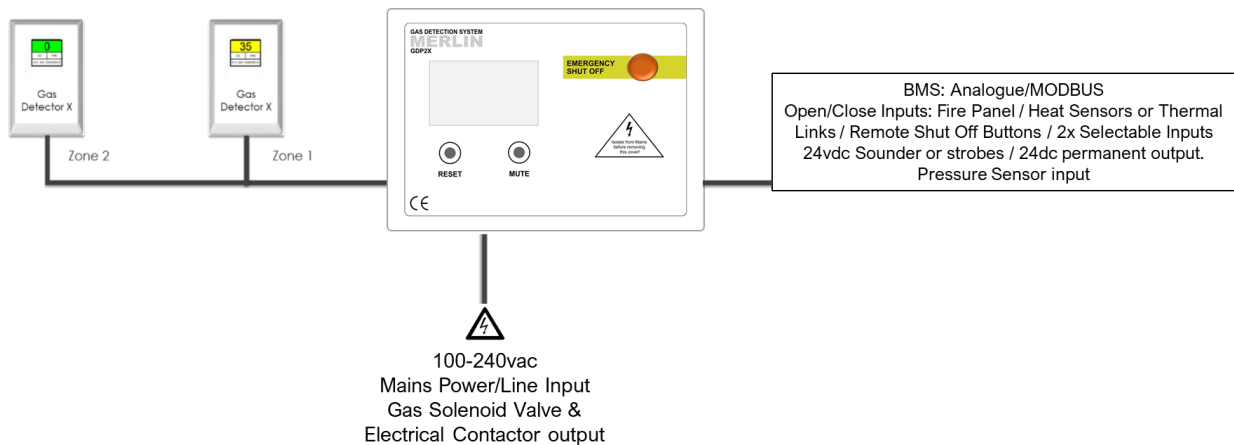

Where detector cable runs may exceed 100 metres from one control panel – Contact your supplier!

The use of sound strobes are highly recommended!

Refer to your detector manual for further information regarding coverage, location and positioning including areas and conditions to avoid!

Access & Mounting

Unpack all the parts!

Designed for surface mounting, it must be installed by a licensed, insured contractor or competent person.

Carefully remove the front cover from the unit by unscrewing the four bolts located at each corner. To do this – use the socket wrench provided. Mark the four screw holes located on the back of the enclosure to the wall and ensure the wall surface is flat to prevent base distortion.

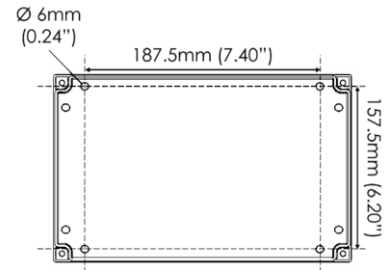

After executing the mounting and the connections – replace the front cover and insert the security caps over the four bolts.



Access to the interior of the panel, when carrying out any work, must be conducted by a competent person. Before carrying out any work ensure local regulations and site procedures are followed.

We recommend all Merlin gas detection equipment and systems are commissioned by a competent/trained engineer to ensure correct installation and operation. Contact S&S Northern for more information.

Internal Board Overview

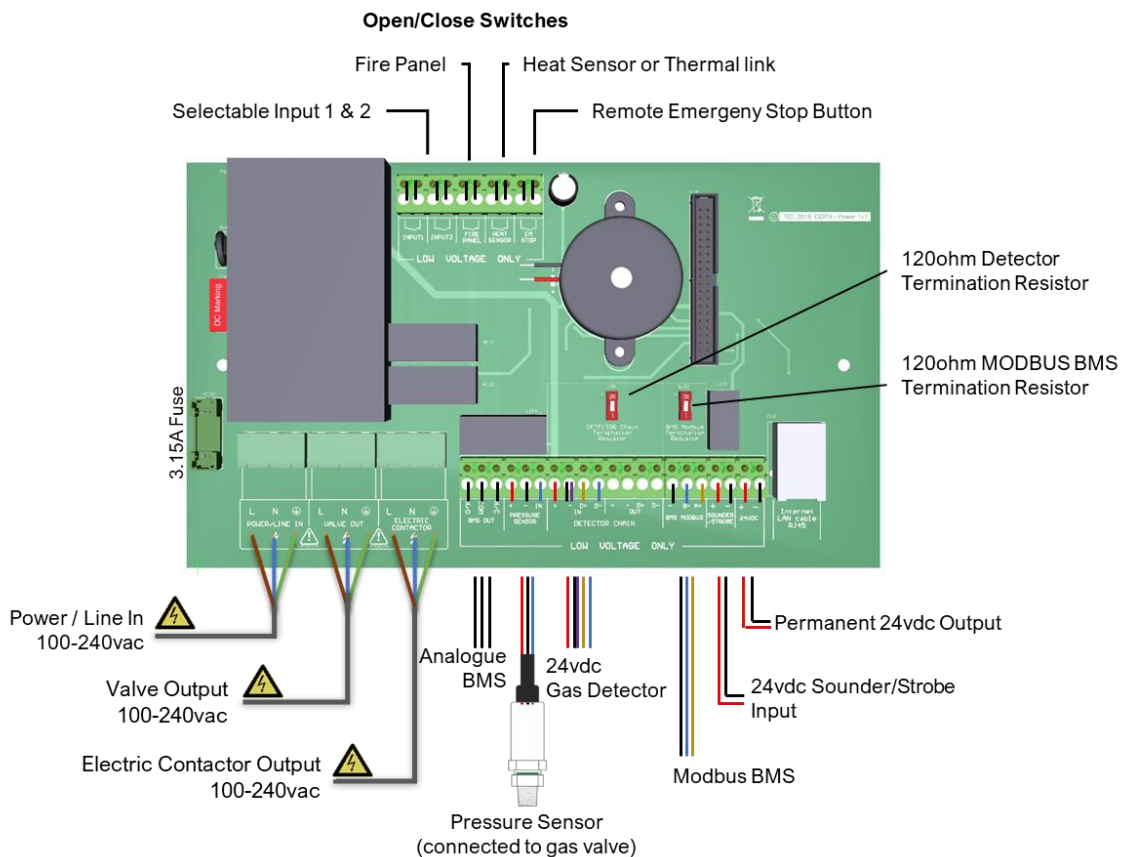

Note: Terminal blocks are plug/socket type and may be removed to ease wiring.



Be careful when creating access for cables – Damage to circuit boards will void any warranty!

Detectors must be earthed/grounded for electrical safety and to limit the effects of EMC or R/F interference.

For MODBUS communications, a shielded cable is used!

Detectors are shipped pre-calibrated and configured!

Board Connections Overview

POWER/LINE IN

100-240vac mains power is supplied to the [POWER/LINE IN] connector using a 3-core cable fused at 3A. On connecting the mains supply to the panel the power LED indicator will light up – this is located on the front.

VALVE OUT

100-240vac electrical power output from the [VALVE OUT] terminal using a 3-core cable to a gas solenoid valve, which can shut the gas supply on alarm status.

ELECTRIC CONTACTOR

100-240vac electrical power output from the [ELECTRIC CONTACTOR] terminal using a 3-core cable, which will isolate electrics in conjunction with the gas supply/line on alarm status.

BMS OUTPUT

Connections are available on the board for Building Management Systems. These are volt free connections.

This is a relay that changes state in alarm or when the gas is on/off and used in conjunction with the 24vdc output and other external relays that affect other devices and controls such as purge fans and audible alarms etc.

PRESSURE SENSOR

The sensor wired to the [PRESSURE SENSOR] connector is screwed into the downstream port of the gas solenoid valve. Wire sensor as follows: Red **[+]** Black **[-]** Blue **[IN]**.

The sensor will monitor the gas supply pressure and if the pressure drops below 12mbar, the gas valve will close as this could mean a gas leak is present. The sensor operating pressure is 0–100mbar.

DETECTOR CHAIN 24vdc power supply and MODBUS communication data cables are wired up to sixteen detectors, chained in parallel up to approx. 100 yards from the panel depending on the chain configuration, wire type for power and condition. For more information, see section: Wiring your detector.

BMS MODBUS

Connections for Master/Slave protocols used in Building Management Systems to communicate between devices including the GDPX+ panel are used with [BMS MODBUS] – RTU.

SOUNDER-STROBE

24vdc output for an external sounder alarm/strobe lighting to activate on alarm.

24V DC OUTPUT

This is a permanent 24V DC power output for external auxiliary devices. Max output: 200mA

INPUT 1 & INPUT 2

These terminals are connections for selectable external devices, which send an 'open/close' circuit signal to the GDP-X panel such as a current monitor, CO2 monitor, or extra emergency shut buttons and heat sensors - selectable in the settings menu.

FIRE PANEL

An open/close switch for fire alarms detailed on the circuit board as [FIRE PANEL].

HEAT SENSOR

An open/close switch for heat sensors/ thermal links detailed as [HEAT SENSOR].

EM STOP

An open/close switch for remote emergency shut-off buttons detailed on the circuit board as [EM STOP].

Wiring your Detector

24vdc power and MODBUS communication cables are wired to terminals marked [DETECTOR CHAIN + - D+ D-].

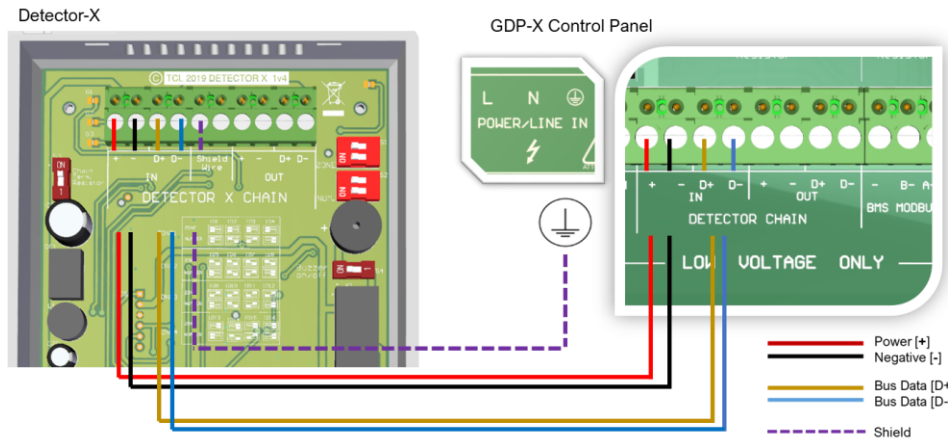

[SHEILD WIRE] detector terminals are used for earthing/grounding and shield wires connected to any earth/ground terminal on the control panel. Twist the shield wire to avoid stray shield wires. If the detector does not have dedicated shield wire terminals, shield wires connect to the 24vdc negative terminal [-] on both detector and panel.

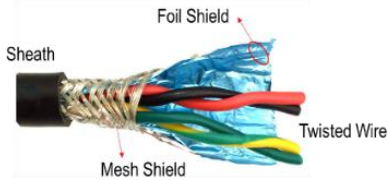

A shielded and twisted 2 or 4 core cable is used to wire the MODBUS terminals [D+ & D-]. The shielding can be of 2 types: braided [mesh of thin conducting wires] or foil (consisting of a thin sheet of metal covering the twisted wires). One example of such cable is BELDEN 3082A. Any cable with similar characteristics can be used to connect all the devices together.

If you are encountering noise or irregular problems with a bus link, the problem is likely related to grounding, incorrect shielding or wiring mains power cables next to data cables.



The detector must be earthed/grounded for electrical safety and limit the effects of R/F & EMC interference!
Where cable runs may exceed 100 metres from one control panel – Contact your supplier!
Ensure the 120-ohm termination resistance switch is turned on at each end of a cable run!

Creating a Detector Chain

Create a detector chain by connecting detectors in a parallel (daisy chain) method. Any other way may cause issues or damage to the overall system. Resistor switches should be turned on at each end of a chain – see section '120ohm Termination Resistance'.

Single Detector Chain from Control Panel example.

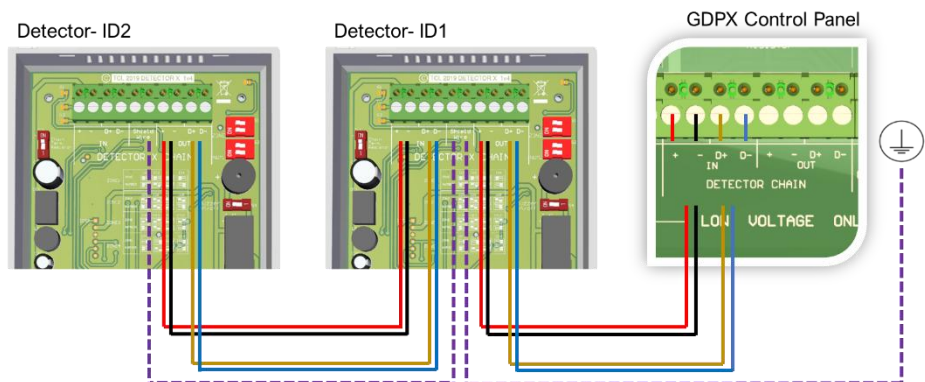

Split Detector Chain from Control Panel example.

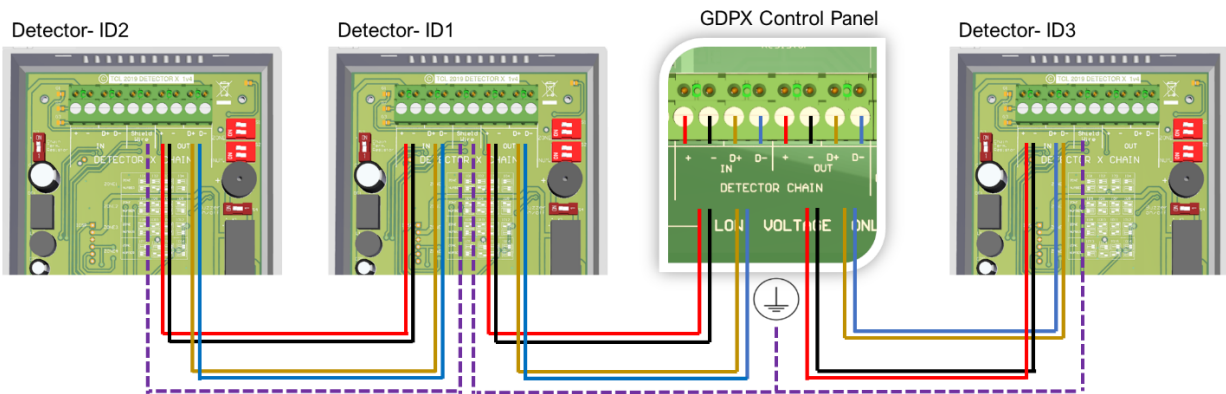

Reversing the [D+] and [D-] connections of any device can lead to the whole system to stop working owing to reverse polarity found on the terminals. In order to avoid this problem, it is recommended that the cable of same colour should be used to connect all [D+] terminals together and similarly cable of same colour to be used to connect all [D-] terminals together.



The detector must be earthed/grounded for electrical safety and limit the effects of R/F & EMC interference! Where cable runs may exceed 100 metres from one control panel – Contact your supplier! Ensure the 120ohm termination resistance switch is turned on at each end of a cable run!

Detector ID Switches

When wiring multiple detectors it is important to identify each detector installed for the control panel to receive and display accurate data corresponding with the correct device.

The ID configuration diagram is printed onto detector boards for quick reference as shown opposite. All detectors are factory set to ID1.



		ID 1	ID 2	ID 3	ID 4
ZONE1	ZONE NUMBER				
		ID 5	ID 6	ID 7	ID 8
ZONE2	ZONE NUMBER				
		ID 9	ID 10	ID 11	ID 12
ZONE3	ZONE NUMBER				
		ID 13	ID 14	ID 15	ID 16
ZONE4	ZONE NUMBER				



We recommend a plan, map and/or marking the detector enclosures detailing ID and location! ID Switches must be configured for each detector connected to receive and display accurate data!

120ohm Termination Resistance – Detector Chains

Signal communication issues may occur where the bus length is too long, high baud rates are used or signal reflections are occurring. To avoid this, terminating at each end of a chain may help the quality of the data signal by turning on the 120-ohm terminal resistor switch.

If a split chain is used, terminate the last detector in each chain.

If a single chain is used, terminate the first device (Panel) and last device (Detector).

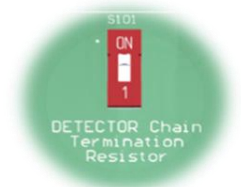

Split chain

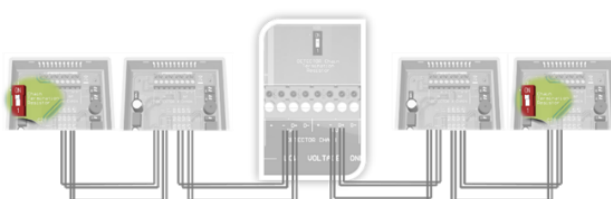

Single chain

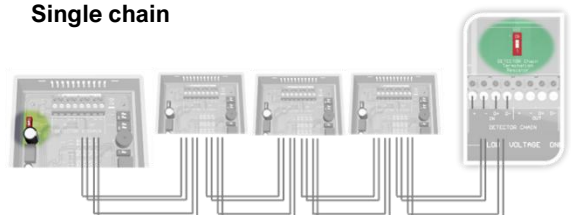

BMS MODBUS

BMS MODBUS for master/slave protocols used in building management systems to communicate between devices including the GDPX+ panel used with [BMS MODBUS] terminal.

A shielded and twisted cable is used. Any cable with similar characteristics is used.

The shielding can be of two types: braided [mesh of thin conducting wires] or foil (consisting of a thin sheet of metal covering the twisted wires). If you are encountering noise or irregular problems with a Modbus link, the problem is likely related to grounding, incorrect shielding or wiring mains power next to Modbus wiring.

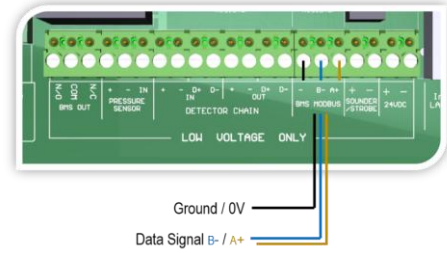

120ohm Termination Resistance – BMS MODBUS

Signal communication issues may occur where the bus length is too long, high baud rates are used or signal reflections are occurring. To avoid this, terminating at each end of a chain may help the quality of the data signal by turning on the 120-ohm BMS terminal resistor switch. Terminate the first and last device in each chain.

MODBUS Data Settings

MODBUS SETUP	Panel Address	Selectable (Default 1)
	Baud rate	Selectable (Default 19200)
	Data bits	8
	Stop bits	2
	Parity	None

DATA SETUP	Function code	03 (Read Holding Register)
	Start address	0 (40001)
	No. of registers (coil)	5
	Data format	16-bit unsigned integral number

03 (Read Holding Register)	
0 (40001)	Panel Status
1 (40002)	Panel Zones Status
2 (40003)	Panel Alarm Status
3 (40004)	Detector X Alarm code
4 (40005)	Gas Pressure (mbar)

Panel Status	1 = GOOD
	2 = PRE-ALARM
	3 = ALARM

Zone Status	0 = DISABLED
	1 = OK
	2 = ATTENTION
	3 = DANGER

Zone Status Example			
Zone1	Zone2	Zone3	Zone4
1	2	0	3
(OK)	(ATTENTION)	(DISABLED)	(DANGER)

Alarm Status	0 = GOOD (No Alarm)
	2 = Fire Panel Alarm
	3 = Heat Sensor Alarm
	4 = Detector
	5 = Emergency Shut Off
	6 = Low Pressure Alarm
	7 = INPUT 1 Alarm
	8 = INPUT 2 Alarm

Alarm Code	11 = Detector X ID 1 Alarm	61 = Detector X ID 1 Fault	111 = Detector X ID 1 Lost
	12 = Detector X ID 2 Alarm	62 = Detector X ID 2 Fault	112 = Detector X ID 2 Lost
	13 = Detector X ID 3 Alarm	63 = Detector X ID 3 Fault	113 = Detector X ID 3 Lost
	14 = Detector X ID 4 Alarm	64 = Detector X ID 4 Fault	114 = Detector X ID 4 Lost
	15 = Detector X ID 5 Alarm	65 = Detector X ID 5 Fault	115 = Detector X ID 5 Lost
	16 = Detector X ID 6 Alarm	66 = Detector X ID 6 Fault	116 = Detector X ID 6 Lost
	17 = Detector X ID 7 Alarm	67 = Detector X ID 7 Fault	117 = Detector X ID 7 Lost
	18 = Detector X ID 8 Alarm	68 = Detector X ID 8 Fault	118 = Detector X ID 8 Lost
	19 = Detector X ID 9 Alarm	69 = Detector X ID 9 Fault	119 = Detector X ID 9 Lost
	20 = Detector X ID 10 Alarm	70 = Detector X ID 10 Fault	120 = Detector X ID 10 Lost
	21 = Detector X ID 11 Alarm	71 = Detector X ID 11 Fault	121 = Detector X ID 11 Lost
	22 = Detector X ID 12 Alarm	72 = Detector X ID 12 Fault	122 = Detector X ID 12 Lost
	23 = Detector X ID 13 Alarm	73 = Detector X ID 13 Fault	123 = Detector X ID 13 Lost
	24 = Detector X ID 14 Alarm	74 = Detector X ID 14 Fault	124 = Detector X ID 14 Lost
	25 = Detector X ID 15 Alarm	75 = Detector X ID 15 Fault	125 = Detector X ID 15 Lost
	26 = Detector X ID 16 Alarm	76 = Detector X ID 16 Fault	126 = Detector X ID 16 Lost

Configuration Settings

On the circuit board is a settings dip-switch, when turned on, the screen will display the settings menu and the system can be configured. The GDPX+ has a touch screen, which allows the engineer/ user to configure the system. There are two menu screens, selectable by touching either page number [1] or [2].

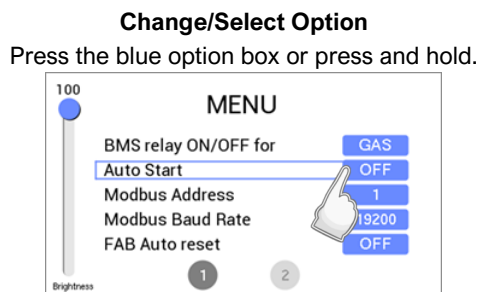
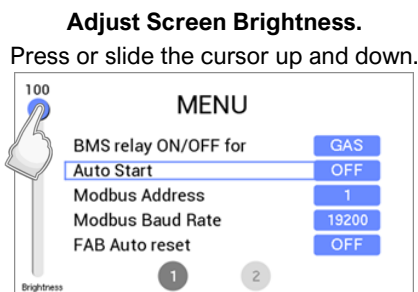

When the system is configured turn the [Settings] switch off and the system will automatically save and restart.



To view, change and save settings, you must provide mains power!

Access to the interior of the detector, when carrying out any work, must be conducted by a competent person!

Before carrying out any work ensure local regulations and site procedures are followed!

Settings Options Explained

FUNCTION	OPTION	<i>Explanation</i>
BMS relay ON/OFF for-	- Gas - Error	Gas changes relay state with gas valve status only. Error changes relay state upon all alarm messages.
Auto Start-	- ON - OFF	In the event of a power loss, the system will restart automatically when restored or not.
Modbus Address-	- 1-32	GDPX+ panel address form master BMS Modbus.
Modbus Baud Rate-	- 9600 - 19200 - 38400 - 57600 - 115200	Modbus data exchange speed (bit per second).
FAB Auto Reset	- ON - OFF	ON: System resets with the fire panel automatically following fire panel alarm. OFF: Manually reset system following fire panel alarm.
INPUT 1 name-	- FAN - NG - CO - LPG - CO2 - EM - HS	External devices connected to [INPUT 1] terminal. Fans (Fan), Gas detectors (NG, CO, LPG, CO2), external emergency stop buttons (EM) or heat sensors (HS).

INPUT 2 name-	- FAN - NG - CO - LPG - CO2 - EM - HS	<i>External devices connected to [INPUT 2] terminal. Fans (Fan), Gas detectors (NG, CO, LPG, CO2), external emergency stop buttons (EM) or heat sensors (HS).</i>
FAB timeout-	- 15 min - 30 min - 45 min	<i>Time that the Fire Alarm Bypass (FAB) feature will be enabled upon each activation.</i>
Fill time	- OFF - 5 sec - 10 sec	<i>Time (seconds) the gas valve is open to fill the gas line on power up or reset. Note: Prove time must be selected.</i>
Prove time-	- OFF - 30 sec - 50 sec	<i>Time (seconds) that the system tests the gas line for leaks on power up or reset. Note: Fill time must be selected.</i>

Factory Set Condition

BMS relay ON/OFF for-	- Gas
Auto Start-	- OFF
Modbus Address-	- 1
Modbus Baud Rate-	- 19200
FAB Auto Reset-	- OFF
INPUT 1 name-	- FAN
INPUT 2 name-	- FAN
FAB timeout-	- 30 min
Fill time-	- 5 sec
Prove time-	- 30 sec

Trouble Shooting

Fault.	Possible Cause/Correction.
Detector not responding.	Incorrect wiring. ID switches not properly configured. Termination switches not set up correctly.
Service message	Detector requires service – contact supplier.
End of Life message	Detector requires replacement – contact supplier.
No internet connection	Contact internet provider. Reset GDPX+.
Gas proving not working	Fill time or gas proving not selected in menu. Both must be ON. Pressure Sensor not connected to downstream port of gas valve.

Operation

First Power Up (Commissioning)

On connecting mains power, the GDP2X panel will 'warm up' for approximately 60 seconds – during this time the screen will display an 'initialisation' message while system searches for detectors wired to the system.



We recommend all gas detection systems be commissioned by a competent/trained engineer to ensure correct installation and operation!

Main Screen

When the system has finished initialising – the main screen will appear. The main screen gives an overview of the status of each zone monitored by gas detectors and if the system is OK.

Zone Status

Zone Status	System Condition
ZONE... OK	Gas levels are safe. No error conditions.
ZONE... ATTENTION	Detector(s) are in pre-alarm status or Detector(s) require service or Detector gas sensor(s) end of life.
ZONE... DANGER	Dangerous gas levels have been detected or Detector gas sensor fault has been detected or Detector has lost its signal with the control panel. See section: Alarm Messages.
ZONE... DISABLED	No detector signals received from the zone.
ZONE... -- X --	Detector not installed or Detector not configured correctly.

Zone Screens

Switch between zone screens by touching the relevant zone screen, i.e. [Z1], [Z2], [Z3] and [Z4]. Each zone can display up to 4 detectors as follows and include the status of alarms and gas levels for each detector:

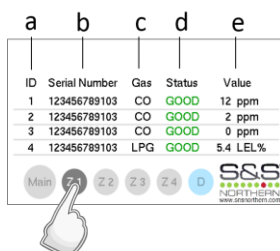

- a. **ID:** The detector identification number.
- b. **Serial Number:** The unique serial number for that detector.
- c. **Gas:** The target gas that the detector is monitoring.
- d. **Status:** The status of gas levels, errors and messages.
- e. **Value:** The concentration value of gas monitored.

Diagnostic Screen

Press the (D) tab on screen to display system diagnostics.

Gas Pressure The pressure sensor connected to the gas solenoid valve will send this data to the panel. If the pressure drops below 12mbar, the system will enter an alarm state after a ten-second delay, as there may be a risk of a gas leak. If proving is off the pressure will not be displayed.

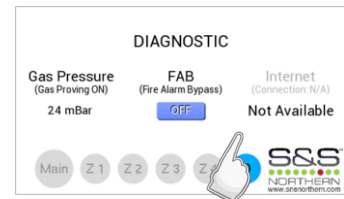

Fire Alarm Bypass (FAB) This is an enable/disable feature where fire alarm tests may be required. To enable the FAB feature select the press the off/on button shown where prompted to confirm the action prior to activation. The FAB feature is displayed on screen when enabled. The system will return to normal at the end of the pre-selected time of 15, 30 or 45 minutes configured in the settings. You can manually disable the FAB by pressing the blue option box to OFF on the diagnostic screen.

Internet Connection status is currently unavailable.

Alarm Messages

When a detector goes into alarm state, the control panel isolate the gas supply and the screen will display the ID of the detector in alarm. If two or more detectors enter alarm status, the first detector to send an alarm signal to the control panel is displayed in the top left hand corner of the screen. Press the relevant zone page for detector information. There are three types of detector alarm.

- Detector Alarm ID: 7
- Detector Fault ID: 6
- Detector Lost ID: 8

Detector **Alarm** ID: #

Dangerous gas levels detected, the control panel will display an **'Alarm'** message and detector ID.

Detector **Fault** ID: #

If the control panel receives a fault signal from a detector, your panel will show a **'Fault'** message and detector ID.

Detector **Lost** ID: #

If a detector loses communication with the control panel, the screen will show a **'Lost'** message.

External Panel Connection Alarms

Alarm messages prompted from external devices connected to relevant open/close terminals on the internal board i.e. remote emergency shut off buttons are visible when in alarm state. The gas supply will isolate (be shut off) and no gas detection details will be available. After the cause of alarm is rectified, press the reset button.



Alarm messages from terminals [INPUT 1] or [INPUT 2] will depend on the name selected in the settings. For example, if CO is the selected input the alarm message will display "CO sensor alarm". If [FAN] is the selected input, you will see "fan fault". All alarm screens will show the input terminal used i.e. Input 1 or Input 2.



Low pressure and fan alarms have a ten-second delay!

All alarms will isolate the gas supply/line and electricians if using an electrical contactor and configured to do so! Pressing mute on the panel will silence the audible alarm buzzer on the panel!

General Maintenance

Cleaning

- ⚠ **Concentrations of alcohol found in many products may damage, deteriorate or affect the gas sensing elements such as; wine; deodorants; stain removers and thinners. Other gases and substances to avoid are corrosives (i.e. chlorine & hydrogen chloride); alkali metals; basic or acidic compounds; silicones; tetraethyl lead; halogens and halogenated compounds!**

Keep your gas detector in good working order - follow these basic principles.

- Remove any dust/debris from the outer enclosure regularly using a slightly damp cloth.
- Never use detergents or solvents to clean your device.
- Never spray air fresheners, hair spray, paint or other aerosols near the device.
- Never paint the device. Paint will seal vents and interfere with the device.

Manual Circuit Simulation Test

- ⚠ **Access to the interior of the detector, when carrying out any work, must be conducted by a competent person!**
- ⚠ **This circuit test does not check the gas-sensing element itself!**

When the test button on the circuit board is pressed and held the detector will simulate an open circuit to ensure configured systems, outputs, alarms, indications, and other external devices operate as intended in response to gas. When the test button is released – the test sequence will terminate and return to normal operation.

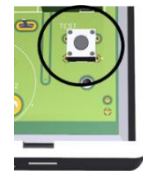

Service Reminders



A service screen will intermittently flash every 30 seconds after one year of operation.

The annual message reminder will begin after five (5) hours of continuous power irrespective of whether the system is then, used intermittently. The detector will still operate as intended during this time.

Depending on the application and environmental factors, a service (bump test) can be conducted at a higher frequency determined by the end user but must be executed by a competent person.

Bump Test (Gas Response Check)

What is a Bump Test?

Gas response checks are often referred to as a 'bump test'. Bump tests are important to make sure a device is able to detect a release of gas as early as possible. The aim of the bump test is to make sure a detector is working at its optimum by briefly exposing the unit to a known concentration of the target gas that usually exceeds the highest alarm point. If the detector goes into alarm and all signals/outputs activate, then the system is working safely.

If the system fails to operate as intended in an alarm state, the gas detector must not be used until a full inspection and service has been conducted.

Why is it important?

A detector may visually appear in good working order, but its sensitivity and accuracy can be inhibited by external factors. Dust, humidity, temperature fluctuations, cleaning products, contaminants, exposure to its target gas or sensor drift (ageing) can cause a decline in sensitivity, accuracy and eventual failure.

How often?

Regular bump tests are important to make sure the detector is able to detect a release of gas as early as possible and usually takes seconds (gas type dependant i.e. CO sensors will take over a minute) and is often completed alongside a scheduled fire alarm test, however the frequency should be determined following an appropriate risk assessment by the end user.

We recommend testing detectors every 12-18 months along with the regular fire test procedures and coincide with the annual service message prompted on the detection system after each year of service/operation.

What do I need?

Contact your S&S representative for details of suitable bump testing kits and gases. Kits usually consist of a certified gas cylinder or spray. We recommend only using S&S calibration gas kits to ensure correct flow rates meet S&S technical requirements. A bump testing gas is usually a concentration mix that exceeds the highest alarm set point.

Standard Test Gases

⚠ All certified test gases supplied by S&S are classified as non-flammable and non-toxic, however, they do contain gas under pressure and may explode if heated to extreme temperatures and cause asphyxiation in high concentrations.

See below for recommended gas concentrations for bump testing your detector.

Detector Type	Standard Test Gas
CO - Carbon Monoxide	350 - 500ppm (balance in air).
NG - Methane	0.6 - 0.8% BV (balance in air)
LPG - Liquid Petroleum Gas	0.3 – 0.4% BV (balance in air)
H - Hydrogen	5000 - 6000ppm (balance in air)
O ₂ - Oxygen	15% (balance in Nitrogen).
CO ₂ – Carbon Dioxide	>4500ppm or Breath on Sensor

Bump Test Procedure

- ⚠ To increase reaction time, cover the escape vents at the top of the device.
- ⚠ For more help and advice on bump testing – contact us.
- ⚠ Always remove the regulator/valve from cylinder after use!
- ⚠ Always check cylinder pressure upon sealing valve – there may not be a sufficient amount of gas!
- ⚠ All S&S cylinders will re-seal upon removal of the regulator/valve!
- ⚠ Always give at least five (5) minutes between testing the same unit or until gas has fully dispersed!
- ⚠ Always consider safety and use equipment in accordance with Safety Data Sheets!

STEP 1

Activate Controller Service Mode – GDP2X & GDPX+

- ⚠ This will inhibit all alarms/outputs and signals for fifteen (15) minutes!
- ⚠ If you are testing all actuation of alarms/outputs and signals please proceed to Step 2!

- Access service mode by pressing the S&S logo on the controller (home screen logo only).
- The screen will display a service message prompt.
- Press Yes. (Note: All alarm signals/outputs will be inhibited for fifteen (15) minutes).
- Proceed to test gas detectors.
- Upon completion – exit service mode by pressing the ‘Exit’ button on screen.



STEP 2**Test Detector**

⚠ Access to the interior of the detector, when carrying out any work, must be conducted by a competent person!

- Ensure you have the correct gas for the device type prior to application.
- Screw and seal the regulator/valve into the gas cylinder outlet.
- Once sealed, the regulator pressure gauge will indicate cylinder pressure.
- Offer up the applicator hose/cone to the lower vents.
- Alternatively, enclose the device and apply gas i.e. in an airtight bag or container.
- Open the valve/regulator to allow the gas to be delivered at a pre-set flow rate.
- Wait for the device to enter alarm status and energise configured outputs/relays.
- At this point...
- Remove applicator hose/ cone and turn the gas cylinder regulator/valve off.
- Wait for the device to return to normal.
- Reset the system.
- Record your test details. There is a provision for this in your control panel manual.

End.

**Reset Service Message**

⚠ Access to the interior of the detector, when carrying out any work, must be conducted by a competent person!

⚠ It is recommended to bump test detector(s) prior to resetting the service reminder message!

1. Carefully remove the detector cover to access the circuit board.
2. Tap the 'test button' 3 times within 2 seconds.
3. The service message on screen will reset.
4. Carefully replace the back cover.

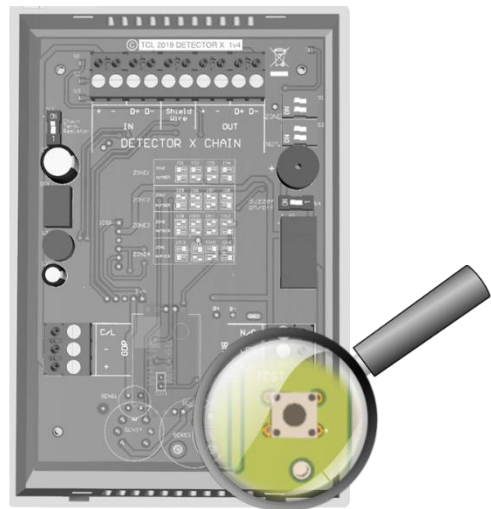

To reset service message
- Tap button 3 times

End of Operational Life (EOL)

⚠ The EOL is approximate from the first five (5) hours of continuous power!

⚠ The EOL will depend on the type of gas your detector is targeting and may vary depending on its application and environmental conditions such as the frequency of exposure to the target gas, poisons or inhibitors!

**END
OF LIFE**

The typical life of a gas detector depends on its application and intended target gas, in addition the operational life can be prolonged if the system and equipment is installed and maintained in accordance the instructions stated within this manual.

At the end of its predicted operational life – the detector will display an 'End of Life' screen. This message indicates that the detector has reached its expected operational lifecycle and no gas levels are displayed.

You must contact your supplier immediately for replacement.

This page is intentionally left blank

This page is intentionally left blank

Specification

General	
Product:	GDPX+: Gas Detection Control Panel
Use:	Indoor, Safe Areas (not to be used in potentially explosive atmospheres)
Indicators (4.3" Touch Screen)	Main Zone Status. ID. Gas Type. Concentration Level. Measured Value. End of Life. Fault. Service.
Screen Brightness	Adjustable 0-100%
Mounting	Wall Mounting
Electrical	
Max. Power Consumption	48W Max (Full Load)
Power Voltage Input Range	100-240vac
Gas Valve Output Range	100-240vac
Electrical Contactor Output Range	100-240vac
I/Os	3x 24vdc Outputs (Detector / Strobe or Sounder / Permanent) 5x Open/Close Switches (EM Stop / Heat Sensor / Fire Panel / 2x Selectable)
BMS Terminal	Volt Free (Normally Closed / Common / Normally Open) 3A Max
Communication	RS485 MODBUS RTU
Relay(s)	3x DPCO 250VAC @ 3A (BMS & VALVE / ELECTRICAL CONTACTOR OUTPUTS)
Terminal Wire ratings	Copper 18AWG (0.75mm ²) Min. 25 x screw terminals.
Fuse	3.15A
Internet (Unavailable)	Ethernet (RJ45)
Construction	
Dimensions (H x W x D)	180 x 255 x 77 mm/ 7.08 x 10.03 x 3"
Unit Weight (Approx.)	1.1kg / 38.8oz
Housing Material	Polylac - PA765
Environmental	
Ingress Protection	IP65 (Pre-installation)
Storage Conditions	Dry. Cool. Flat
Operating Conditions	-10 ~ 50°C / 14 ~ 122°F 30 ~ 80% rf
Compliance	
CE / UKCA	EN 61326-1 / BS EN IEC 61010-1

Installation Details

Please pass this manual to the system owner / user.

Date of Installation:	
Installation Location:	
Organisation:	
Stamp/Signature of the installer:	

We recommend all Merlin gas detection equipment be commissioned by a competent/trained engineer to ensure correct installation and operation. The Merlin range of gas detectors are calibrated when manufactured, however, we strongly recommend the detectors response and alarm signals are tested and validated once installed. This will ensure the equipment performs as intended and is free from any unforeseen damage caused by transit/installation.

Every effort is made to ensure the accuracy of this document; however, S&S Northern can assume no responsibility for any errors or omissions in this document or their consequences. S&S Northern would greatly appreciate being informed of any errors or omissions that may be found in the content of this document. For information not covered in this document, or if there is a requirement to send comments/corrections, please contact S&S Northern using the contact details given below.

S&S Northern Head Office

Tel: +44(0) 1257 470 983
 Fax: +44(0) 1257 471 937
www.snsnorthern.com
info@snsnorthern.com

Southeast Division

Tel: +44(0) 1702 291 725
 Fax: +44(0) 1702 299 148
south@snsnorthern.com



S&S Northern is the owner of this document and reserves all rights of modification without prior notice.